

IBM Remote Support Manager for Storage Version 2.8



# Planning, Installation, and User's Guide



IBM Remote Support Manager for Storage Version 2.8



# Planning, Installation, and User's Guide

**Note:**

Before using this information and the product it supports, be sure to read the information in "Notices" on page 87.

**First Edition (April 2012)**

**© Copyright IBM Corporation 2012.**

US Government Users Restricted Rights – Use, duplication or disclosure restricted by GSA ADP Schedule Contract with IBM Corp.

---

# Contents

<b>Figures</b> . . . . .	vii
<b>Tables</b> . . . . .	ix
<b>Safety</b> . . . . .	xi
<b>About this document</b> . . . . .	xiii
Who should read this document . . . . .	xiii
How this document is organized . . . . .	xiii
Notices and statements used in this document . . . . .	xiii
Getting information, help, and service . . . . .	xiv
Before you call . . . . .	xiv
Using the documentation . . . . .	xiv
Web sites . . . . .	xv
Hardware service and support . . . . .	xv
Fire suppression systems . . . . .	xv
Modem performance/failure criteria . . . . .	xvi
<b>Chapter 1. Planning for RSM for Storage</b> . . . . .	1
What RSM for Storage does . . . . .	1
Supported products. . . . .	2
Storage subsystems . . . . .	2
Storage management applications . . . . .	2
Other SAN devices . . . . .	2
How many do I need?. . . . .	2
Prerequisite hardware . . . . .	2
Server platform . . . . .	2
Methods for Remote Access . . . . .	3
Remote Access via Modem. . . . .	3
Remote Access via SSH . . . . .	3
Prerequisite software . . . . .	4
Network connections . . . . .	4
Sending alerts to IBM . . . . .	4
Local management via SSH . . . . .	6
Optional external SSH connection . . . . .	6
Ports used by RSM for Storage . . . . .	7
TCP Ports . . . . .	7
INPUT . . . . .	7
OUTPUT . . . . .	8
Allowed ICMP types . . . . .	8
Preparing for installation . . . . .	9
Site Preparation . . . . .	9
Remote Access . . . . .	9
Local Access . . . . .	9
Information you will need . . . . .	9
Information used during the installation of the operating system . . . . .	9
Information used during configuration of RSM for Storage . . . . .	10
<b>Chapter 2. Installation overview</b> . . . . .	13
Hardware installation. . . . .	13
VMware environments . . . . .	13
Virtual Client configuration. . . . .	13
RSM for Storage configuration . . . . .	13

Servers . . . . .	13
Updating the server firmware . . . . .	14
Modem . . . . .	14
Software installation . . . . .	15
<b>Chapter 3. Installing RSM for Storage . . . . .</b>	<b>17</b>
Starting the installation from a CD . . . . .	17
Installation steps . . . . .	17
<b>Chapter 4. Configuration . . . . .</b>	<b>21</b>
Configuring RSM for Storage . . . . .	21
IBM DS Storage Manager . . . . .	23
Turn off automatic collection of support data . . . . .	23
Configure SNMP traps to be sent to the Remote Support Manager . . . . .	23
DS Storage Manager passwords . . . . .	24
Shell access Security . . . . .	24
Verify Remote Access connectivity . . . . .	24
SSH connectivity . . . . .	24
Modem connectivity . . . . .	25
Communication between the modem and server . . . . .	25
Remote access to the modem . . . . .	25
Activation . . . . .	25
Activating when you have enabled 'One-Way Call Home' . . . . .	26
Backing up your configuration . . . . .	27
<b>Chapter 5. Installing updates to RSM for Storage . . . . .</b>	<b>29</b>
Updating the RSM for Storage using a ZIP file . . . . .	29
Updating RSM for Storage using a CD-ROM . . . . .	30
<b>Chapter 6. Using RSM for Storage . . . . .</b>	<b>33</b>
User IDs and desktops . . . . .	33
Icons . . . . .	33
Notification e-mails . . . . .	33
E-mail contacts . . . . .	34
Browser interface . . . . .	35
Management pages . . . . .	35
System configuration . . . . .	35
Firewall . . . . .	36
Remote access . . . . .	36
Reporting and alerts . . . . .	37
Navigation links and status summary . . . . .	38
Help pages . . . . .	38
Configuration procedures and issues . . . . .	39
Adding a new subsystem . . . . .	39
E-mail Transport options . . . . .	39
Changing who emails appear to be from . . . . .	39
Changing the from root field on e-mails . . . . .	39
Changing to domain used to send e-mails . . . . .	40
Changing who receives e-mails . . . . .	40
Changing passwords . . . . .	40
Saving and restoring configuration files . . . . .	40
Saving the configuration files . . . . .	40
Restoring saved configuration files . . . . .	41
Power off/on sequence . . . . .	41
Working with IBM Service . . . . .	41
Enabling remote access . . . . .	41

Acknowledging alerts . . . . .	41
Closing alerts . . . . .	42
Remote access timeout. . . . .	42
Providing additional privileges . . . . .	42
Performance issues or other concerns that do not trigger an alert . . . . .	42
Event filtering and handling . . . . .	43
Ignored Events . . . . .	43
Duplicates . . . . .	43
Security . . . . .	43
Access to the RSM for Storage system . . . . .	43
Scope of access to your network . . . . .	44
User permissions and privileges . . . . .	44
Password complexity for the browsers interface . . . . .	44
IP connections . . . . .	45
Firewall states . . . . .	45
Side effects of the firewall operation . . . . .	46
Customizing the firewall . . . . .	46
Managing the system using SSH . . . . .	46
Log in to SAN devices . . . . .	47
Information sent to IBM. . . . .	47
Enabling One-way Call Home . . . . .	47
<b>Chapter 7. Troubleshooting.</b> . . . . .	<b>49</b>
Hardware problems with the server . . . . .	49
Remote Support Manager interactions with server problem determination . . . . .	50
To stop the Remote Support Manager . . . . .	50
To re-start the Remote Support Manager . . . . .	50
General tips for troubleshooting problems with System x servers . . . . .	50
Problems with the external modem . . . . .	50
Quick physical checks . . . . .	50
None of the indicators light . . . . .	51
Configuration test problems . . . . .	51
Possible causes of a configuration test error . . . . .	51
Verifying the Serial port is enabled in the BIOS . . . . .	52
The modem will not answer . . . . .	52
The Phone Line Check fails . . . . .	52
Problems with operation of the RSM for Storage . . . . .	52
Configuration problems . . . . .	53
Other problems. . . . .	53
Icons for RSM for Storage on the desktop are missing or do not work . . . . .	53
Events for a subsystem are not reported by RSM for Storage. . . . .	53
RSM does not indicate a problem that appears in DS Storage Manager . . . . .	54
Multiple e-mails about the same problem . . . . .	54
A problem detected by the RSM for Storage software, but no e-mail was sent and the status of the alert is "Queued" . . . . .	55
E-mail received that said the event was ignored and not sent to IBM Service . . . . .	55
After an earlier problem was resolved, the RSM stopped sending alerts to IBM . . . . .	55
I/O error message in IBM DS Storage Manager when trying to validate SNMP trap configuration . . . . .	55
Log files are not sent to IBM . . . . .	55
Calling for help . . . . .	55
Sending log files for RSM for Storage to IBM. . . . .	55
<b>Appendix A. Installing the SLES 11 operating system</b> . . . . .	<b>57</b>

Part 1 – SLES 11 installation . . . . .	57
Part 2- SLES 11 installation . . . . .	57
Part 3- SLES 11 installation . . . . .	57
<b>Appendix B. Installing the SLES 10 operating system . . . . .</b>	<b>63</b>
Part 1 – SLES 10 installation . . . . .	63
Part 2- SLES 10 installation . . . . .	63
Part 3- SLES 10 installation . . . . .	63
<b>Appendix C. Installing the RHEL 4 AS, Update 4 or Update 5 operating system . . . . .</b>	<b>69</b>
Part 1 – RHEL 4 AS, Update 4 or Update 5 installation . . . . .	69
Part 2- RHEL 4 installation . . . . .	69
Part 3- RHEL 4 installation . . . . .	69
<b>Appendix D. Installing the RHEL 5 operating system. . . . .</b>	<b>73</b>
Part 1 – RHEL 5 installation . . . . .	73
Part 2- RHEL 5 Installation . . . . .	73
Part 3- RHEL 5 Installation . . . . .	73
RHEL 5 - Configuration . . . . .	75
<b>Appendix E. Planning worksheets . . . . .</b>	<b>77</b>
Worksheet #1: Network setup information for the RSM for Storage server . . . . .	77
Worksheet #2: Company information . . . . .	77
Worksheet #3: Connection information for the RSM for Storage system . . . . .	78
Worksheet #4: Contact people . . . . .	79
Contact #__ . . . . .	79
Contact #__ . . . . .	79
Contact #__ . . . . .	79
Worksheet #5: Information for each Storage Subsystem. . . . .	80
Storage subsystem #__. . . . .	80
Worksheet #6: Information for other SAN devices to be accessible from the RSM for Storage system . . . . .	82
<b>Appendix F. Filtered events. . . . .</b>	<b>83</b>
<b>Appendix G. Customizing the firewall. . . . .</b>	<b>85</b>
<b>Notices . . . . .</b>	<b>87</b>
Trademarks . . . . .	88
<b>Index . . . . .</b>	<b>89</b>



---

## Figures

1.	Network connection topology . . . . .	7
2.	Serial port connection . . . . .	14
3.	Network Configuration . . . . .	19
4.	Example of a configured system . . . . .	27
5.	Patterns selection window . . . . .	58
6.	Filter: Search selection window . . . . .	59
7.	Patterns selection window . . . . .	64
8.	Filter: Search selection window . . . . .	65



---

## Tables

1.	IP addresses of IBM . . . . .	5
2.	IP addresses for ECC Client reporting . . . . .	5
3.	Allowed ICMP types . . . . .	8
4.	E-mail contacts . . . . .	34
5.	Status summary icons . . . . .	38
6.	Drive enclosures . . . . .	80
7.	SAN devices . . . . .	82
8.	Filtered events. . . . .	83



## Safety

Before installing this product, read the Safety Information.

قبل تركيب هذا المنتج، يجب قراءة الملاحظات الأمنية

Antes de instalar este produto, leia as Informações de Segurança.

在安装本产品之前，请仔细阅读 **Safety Information**  
(安全信息)。

安裝本產品之前，請先閱讀「安全資訊」。

Prije instalacije ovog produkta obavezno pročitajte Sigurnosne Upute.

Před instalací tohoto produktu si přečtěte příručku bezpečnostních instrukcí.

Læs sikkerhedsforskrifterne, før du installerer dette produkt.

Lees voordat u dit product installeert eerst de veiligheidsvoorschriften.

Ennen kuin asennat tämän tuotteen, lue turvaohjeet kohdasta Safety Information.

Avant d'installer ce produit, lisez les consignes de sécurité.

Vor der Installation dieses Produkts die Sicherheitshinweise lesen.

Πριν εγκαταστήσετε το προϊόν αυτό, διαβάστε τις πληροφορίες ασφάλειας  
(safety information).

לפני שתתקינו מוצר זה, קראו את הוראות הבטיחות.

A termék telepítése előtt olvassa el a Biztonsági előírásokat!

Prima di installare questo prodotto, leggere le Informazioni sulla Sicurezza.

製品の設置の前に、安全情報をお読みください。

본 제품을 설치하기 전에 안전 정보를 읽으십시오.

Пред да се инсталира овој продукт, прочитајте информацијата за безбедност.

Les sikkerhetsinformasjonen (Safety Information) før du installerer dette produktet.

Przed zainstalowaniem tego produktu, należy zapoznać się  
z książką "Informacje dotyczące bezpieczeństwa" (Safety Information).

Antes de instalar este produto, leia as Informações sobre Segurança.

Перед установкой продукта прочтите инструкции по  
технике безопасности.

Pred inštaláciou tohto zariadenia si pečítajte Bezpečnostné predpisy.

Pred namestitvijo tega proizvoda preberite Varnostne informacije.

Antes de instalar este producto, lea la información de seguridad.

Läs säkerhetsinformationen innan du installerar den här produkten.

## Statement 1



### DANGER

**Electrical current from power, telephone, and communication cables is hazardous.**

**To avoid a shock hazard:**

- **Do not connect or disconnect any cables or perform installation, maintenance, or reconfiguration of this product during an electrical storm.**
- **Connect all power cords to a properly wired and grounded electrical outlet.**
- **Connect to properly wired outlets any equipment that will be attached to this product.**
- **When possible, use one hand only to connect or disconnect signal cables.**
- **Never turn on any equipment when there is evidence of fire, water, or structural damage.**
- **Disconnect the attached power cords, telecommunications systems, networks, and modems before you open the device covers, unless instructed otherwise in the installation and configuration procedures.**
- **Connect and disconnect cables as described in the following table when installing, moving, or opening covers on this product or attached devices.**

<b>To Connect:</b>	<b>To Disconnect:</b>
<ol style="list-style-type: none"><li>1. Turn everything OFF.</li><li>2. First, attach all cables to devices.</li><li>3. Attach signal cables to connectors.</li><li>4. Attach power cords to outlet.</li><li>5. Turn device ON.</li></ol>	<ol style="list-style-type: none"><li>1. Turn everything OFF.</li><li>2. First, remove power cords from outlet.</li><li>3. Remove signal cables from connectors.</li><li>4. Remove all cables from devices.</li></ol>

---

## About this document

This guide provides details about planning, installation and using the IBM® Remote Support Manager for Storage (RSM for Storage) software.

---

## Who should read this document

This document is intended for system operators and service technicians who have extensive knowledge of fibre channel and network technology.

---

## How this document is organized

This document is organized as follows:

Chapter 1, “Planning for RSM for Storage,” on page 1 provides an overview of RSM for Storage and planning details to help you configure RSM for Storage.

Chapter 2, “Installation overview,” on page 13 provides instructions for installing the hardware and software necessary for using RSM for Storage.

Chapter 3, “Installing RSM for Storage,” on page 17 provides instructions for installing RSM for Storage.

Chapter 4, “Configuration,” on page 21 provides instructions for configuring RSM for Storage.

Chapter 5, “Installing updates to RSM for Storage,” on page 29 provides instructions for installing updates to RSM for Storage.

Chapter 6, “Using RSM for Storage,” on page 33 provides an overview of the RSM for Storage programs, details on the different types users for RSM for Storage, and information about managing the RSM for Storage software.

Chapter 7, “Troubleshooting,” on page 49 addresses problems with the server that the Remote Support Manager is running on.

Appendix B, “Installing the SLES 10 operating system,” on page 63 provides instructions for installing the SLES 10 operating system.

Appendix A, “Installing the SLES 11 operating system,” on page 57 provides instructions for installing the SLES 11 operating system.

Appendix C, “Installing the RHEL 4 AS, Update 4 or Update 5 operating system,” on page 69 provides instructions for installing the RedHat RHEL 4 operating system.

Appendix D, “Installing the RHEL 5 operating system,” on page 73 provides instructions for installing the RHEL 5 operating system.

Appendix E, “Planning worksheets,” on page 77 provides worksheets to help you gather the necessary information to successfully install and configure RSM for Storage.

Appendix F, “Filtered events,” on page 83 provides a list of events that are not reported to IBM Service.

Appendix G, “Customizing the firewall,” on page 85 provides details to help you customize the firewall settings.

---

## Notices and statements used in this document

The caution and danger statements used in this document also appear in the multilingual *IBM Safety Information* document provided with your Remote Support Manager for Storage product. Each caution and danger statement is numbered for easy reference to the corresponding statements in the safety document.

The following types of notices and statements are used in this document:

- **Note:** These notices provide important tips, guidance, or advice.
- **Important:** These notices provide information or advice that might help you avoid inconvenient or problem situations.
- **Attention:** These notices indicate possible damage to programs, devices, or data. An attention notice is placed just before the instruction or situation in which damage could occur.
- **Caution:** These statements indicate situations that can be potentially hazardous to you. A caution statement is placed just before the description of a potentially hazardous procedure step or situation.
- **Danger:** These statements indicate situations that can be potentially lethal or extremely hazardous to you. A danger statement is placed just before the description of a potentially lethal or extremely hazardous procedure step or situation.

---

## Getting information, help, and service

If you need help, service, or technical assistance or just want more information about IBM products, you will find a wide variety of sources available from IBM to assist you. This section contains information about where to go for additional information about IBM and IBM products, what to do if you experience a problem with your RSM for Storage system, and whom to call for service, if it is necessary.

### Before you call

Before you call, make sure that you have taken these steps to try to solve the problem yourself:

- Check all cables to make sure that they are connected.
- Check the power switches to make sure that the system is turned on.
- Use the troubleshooting information in your system documentation and use the diagnostic tools that come with your system.
- Check for technical information, hints, tips, and new device drivers at the following Web site:  
[www.ibm.com/storage/techsup.htm](http://www.ibm.com/storage/techsup.htm)
- Use an IBM discussion forum on the IBM Web site to ask questions.

You can solve many problems without outside assistance by following the troubleshooting procedures that IBM provides in the online help or in the documents that are provided with your system and software. The information that comes with your system also describes the diagnostic tests that you can perform. Most System x<sup>®</sup> systems, operating systems, and programs come with information that contains troubleshooting procedures and explanations of error messages and error codes. If you suspect a software problem, see the information for the operating system or program.

### Using the documentation

Information about the System x system and preinstalled software, if any, is available in the documents that come with your system. This includes printed documents, online documents, README files, and help files. See the troubleshooting information in your system documentation for instructions on how to use the diagnostic programs. The troubleshooting information or the diagnostic programs might tell you that you need additional or updated device drivers or other software.



## Web sites

IBM maintains pages on the World Wide Web where you can get the latest technical information and download device drivers and updates.

- For storage subsystem information, go to the following Web site:  
[www.ibm.com/servers/storage/support/disk/](http://www.ibm.com/servers/storage/support/disk/)  
The support page has many sources of information and ways for you to solve problems, including:
  - Diagnosing problems using the IBM Online Assistant
  - Downloading the latest device drivers and updates for your products
  - Viewing frequently asked questions (FAQ)
  - Viewing hints and tips to help you solve problems
  - Participating in IBM discussion forums
  - Setting up e-mail notification of technical updates about your products
- For the latest information about IBM System x products, services, and support, go to the following Web site:  
[www.ibm.com/eserver/xseries/](http://www.ibm.com/eserver/xseries/)
- You can order publications through the IBM Publications Ordering System at the following Web site:  
[www.elink.ibm.com/public/applications/publications/cgibin/pbi.cgi/](http://www.elink.ibm.com/public/applications/publications/cgibin/pbi.cgi/)

## Hardware service and support

You can receive hardware service through IBM Integrated Technology Services. Go to the following Web site for support telephone numbers:

[www.ibm.com/planetwide/](http://www.ibm.com/planetwide/)

Service is available for storage subsystems attached to the RSM for Storage system according to the same terms and conditions of the maintenance agreement or warranty in effect for the attached subsystems.

All subsystems to be monitored by the RSM for Storage software must be within warranty or covered by a current maintenance agreement.

## Fire suppression systems

A fire suppression system is the responsibility of the customer. The customer's own insurance underwriter, local fire marshal, or a local building inspector, or both, should be consulted in selecting a fire suppression system that provides the correct level of coverage and protection. IBM designs and manufactures equipment to internal and external standards that require certain environments for reliable operation. Because IBM does not test any equipment for compatibility with fire suppression systems, IBM does not make compatibility claims of any kind nor does IBM provide recommendations on fire suppression systems.

RSM for Storage does not report fires or potential fires.

## Modem performance/failure criteria

This applies to the internal modem that is shipped with the DS-RSM hardware/software bundle. The MT9234ZPX-UPCI modem adheres to the ITU V.34 standard. As part of ITU V.34 standard and based on line quality, the modem can and will periodically go through a series of retrain and rate renegotiation processes. These processes allow the modem to maintain a connection and data integrity. When less than perfect line conditions exist, the retrain and rate renegotiation processes typically will not exceed two minutes to reach a level where the modem can transmit or receive data again. When this occurs, the modem is performing according to the ITU standard, so the delay in the transmission or receipt of data is not considered a failure. Under extremely poor line conditions, the modem might not be able to renegotiate to a level that allows for the transmission or receipt of data and it will eventually give up. If this occurs, the network connection is dropped and the modem is placed on-hook. Disconnecting from the network is considered a failure and is indicated by a no carrier message.

---

## Chapter 1. Planning for RSM for Storage

This chapter provides an overview of RSM for Storage and planning details to aid in the configuration of RSM for Storage.

**Note:** Please refer to the *RSM for Storage - Hints and Tips* document for recent updates or corrections to this manual. The *Hints and Tips* document is available at [www.ibm.com/storage/disk/rsm](http://www.ibm.com/storage/disk/rsm).

---

### What RSM for Storage does

The IBM Remote Support Manager for Storage (RSM for Storage) software installs on an IBM System x server running Novell SUSE Linux Enterprise Server 9, SUSE Linux Enterprise Server 10, Red Hat Enterprise Linux 4 Advanced Server, or Red Hat Enterprise Linux 5 and provides problem reporting and remote access for IBM Service for the DS3000, DS4000<sup>®</sup> and DS5000 families of IBM storage subsystems.

The problem reporting provided by RSM for Storage automatically creates an entry in IBM's call management system for each subsystem that reports a problem. This is the equivalent of placing a voice call to IBM Service for a problem. Once in IBM's call management system, problems are responded to with the same priority as specified by the maintenance agreement in place for the product.

RSM for Storage controls security for remote access by managing hardware and software components of the server it is installed on. Once installed, the server should be considered a single purpose appliance for problem reporting and remote access support for your storage subsystems. Only applications approved by IBM and specified in this document should be installed. (Management of the internal firewall and other configuration changes made by the software might prevent other applications from working.) There is no guarantee that applications that work with the current version of RSM for Storage will continue to work with future releases.

Remote access to the RSM for Storage system by IBM Support is provided by either an external modem attached to the server or via an external SSH connection. This connection provides IBM Service with a command-line interface to the server. All bulk data transfers for logs and other problem determination files are sent to IBM via e-mail using the server's Ethernet interface. Isolation of remote and local users of the system from other devices on your intranet is performed by an internal firewall that is managed by the RSM for Storage software. Local and remote IBM users of the system do not have the ability to change any security features of the software.

Monitoring of storage subsystems is performed by your existing IBM DS Storage Manager software which is configured to send SNMP traps to the Remote Support Manager when critical events are detected. Configuration of the management application is addressed later in this document.

The RSM for Storage user interface allows you to control and view status of four management areas:

- System configuration
- Reporting
- Remote access
- Internal firewall

Your configured contact person for RSM for Storage will also receive e-mails of status changes in these areas.

---

## Supported products

The RSM for Storage software supports the subsystems, management applications and other SAN devices outlined in the following sections.

## Storage subsystems

The RSM for Storage software supports the DS3000, DS4000, and DS5000 families of mid-range storage subsystems and EXP500 subsystems. The storage subsystems must be covered under warranty or a current IBM maintenance agreement to be eligible to use the RSM for Storage software.

## Storage management applications

The RSM for Storage software works with the Event Monitor of IBM DS Storage Manager. While you can use other applications for routine management of your storage subsystems, DS Storage Manager's Event Monitor must be running.

## Other SAN devices

While RSM for Storage does not support problem reporting for other SAN devices (such as switches), you can specify other devices in the RSM for Storage configuration in order to permit IBM Service to access the management ports of these devices for problem determination. Remote access to these devices must be enabled by the administrator of RSM for Storage when access is required.

---

## How many do I need?

One RSM for Storage system can support up to 50 subsystems. The RSM for Storage system must have IP connectivity to the Ethernet management ports of the subsystems.

If your storage is spread geographically across many time zones, and you do not have 24 hours coverage by administrative users, it may be desirable to have more than one RSM for Storage system.

RSM for Storage system must not require authorization through a firewall in order to access storage subsystems or your company's e-mail server.

---

## Prerequisite hardware

The RSM for Storage software has the following hardware prerequisites.

### Server platform

RSM for Storage can be run on a dedicated IBM System x server or in a VMware client running on a System x server. Please refer to the *RSM for Storage Compatibility Guide* for the minimum server requirements and a list of the specific servers that have been tested with the RSM software.

If you choose to use a System x server that has not been specifically tested with the RSM software, the setup and configuration of the server's BIOS, and installation of the Linux operating system may be different than what is included in the documentation for the RSM software. You will need to contact IBM System x support for questions related to these other servers.

**Notes:**

1. IBM databases for heartbeat monitoring (and future changes to IBM authentication requirements for problem reporting) require that connecting systems have a valid IBM Machine Type and Serial Number.
2. The internal firewall that runs on the RSM for Storage server will prevent the use of this server as a general purpose management station. For more information about operating the internal firewall, see “Security” on page 43.
3. RSM for Storage has been tested for operation in a VMware virtual client. Refer to Chapter 2, “Installation overview,” on page 13.

## Methods for Remote Access

The Remote Access for IBM support can be provided by one or both of two methods. An external modem can be attached to the server's serial port, or remote access via an SSH client can be enabled.

### Remote Access via Modem

The functional requirements for the modem are minimal; it is only used for remote access by IBM Support. Most "Hayes-compatible" external modems can be used. The modem should have a minimum speed of 56 Kbps supporting either V.90 or V.92, and support the following "AT" commands:

ATH0	Hangup
Z	Reset to default settings
&W	Save as default
S0=0	Do not answer
D	Dial
&F	Load factory default
I3	Report software version
I4	Report product information
V1	Report results in word form
X3	Report all results, but disable dial tone detection
X4	Report all results with dial tone detection

Be sure to use a modem and power cord appropriate for your country or region.

The RSM for Storage software has been tested with the following modems:

- Multitech Multimodem® II MT5600BA
- Multitech MultiModem ZBA MT5634ZBA

Refer to the *RSM for Storage Compatibility Guide* for updated information about which modems are supported.

You will need to contact your IT support staff for installation and problem resolution related to the modem.

Your modem may be supplied with a RJ-11 phone cord. You may need to supply an adapter in order to connect the RJ-11 phone cord to your phone system.

### Remote Access via SSH

If you choose to allow IBM Support external access to the RSM for Storage system using a secure shell client (SSH), then a modem will not be required. You can also choose to allow remote access by both methods. More information on setting up and using an SSH connection is available in “Network connections” on page 4.

---

## Prerequisite software

RSM for Storage software is supported on Novell SuSE Linux Enterprise Server (SLES) 10 and 11; Red Hat Enterprise Linux (RHEL) 4 and 5. Refer to the *RSM for Storage Compatibility Guide* for specific service packs and updates that are supported. RSM for Storage software will not install on unsupported versions.

RSM for Storage software is designed to install on the standard Linux distributions listed above and with the configuration specified in the installation chapter of this document. Installation or activation of programs, services or applications not specifically listed in this document may not work as expected, or may interfere with the operation of RSM for Storage.

RSM for Storage software receives SNMP traps from the Event Monitor included with IBM DS Storage Manager. RSM for Storage software cannot be installed on the same system used to manage your storage network. Your management station must have IBM DS Storage Manager 9.16 or later installed. It is recommended that you always use the latest version of IBM DS Storage Manager and controller firmware that is available.

---

## Network connections

The RSM for Storage system requires an Ethernet connection to the management ports of the storage subsystems to be monitored and the management station running IBM DS Storage Manager's Event Monitor.

It also requires an Ethernet connection to the Internet, DNS and usually your SMTP server. If your SAN management LAN is separate from your intranet (which provides access to the Internet), you will need a second Ethernet port or adapter in the RSM for Storage server.

**Note:** Check the RSM for Storage - Installation Hints and Tips document for the most current information regarding IP addresses and Ports used by RSM for Storage. This document is available on-line on the download page at [www.ibm.com/storage/disk/rsm](http://www.ibm.com/storage/disk/rsm)

## Sending alerts to IBM

RSM for Storage can send alerts to IBM Service by two methods. The primary method, available in version 2.x and later, is to establish a HTTPS connection directly to the IBM Problem Reporting and Status Reporting servers. This method provides confirmation of receipt and encryption of all information. This method uses the IBM Electronic Customer Care (ECC) client. If you are upgrading from version 1.x, you will notice additional components and references to ECC during installation and in log files. ECC client also creates new status values which will be seen on the browser management pages. If a direct connection can not be established, RSM for Storage will send alerts to IBM's email gateway with log files as attachments. This was the reporting method used in versions 1.x of RSM for Storage software.

**Notes:**

1. In order to obtain Support Data from the storage subsystems, the RSM for Storage system should not require authorization through a firewall in order to access storage subsystems.
2. If you are using the ECC Client for problem reporting, you can configure the ECC Client to use HTTPS proxy for accessing the Internet and IBM service

machines. The proxy configuration requires an IP Address and port number for the proxy server. You can also supply a user id and password if required by your proxy server.

3. When email is used for sending alerts, log files are sent as attachments. The log files are in ZIP format and could possibly be filtered by your e-mail filter. For additional information, see “E-mail Transport options” on page 39. Even if the ECC Client is used for reporting, there are two reasons why RSM for Storage needs to be able to send emails outside your network:
  - a. Email can be used as an alternate reporting path if a connection to the ECC Servers can not be established.
  - b. For troubleshooting problems with operation of the RSM for Storage, a dump of RSM for Storage logs and configuration can be sent via email to IBM Support.

Before installing RSM for Storage, make sure that your company's email server/filter will not block SMTP mail from the RSM for Storage server do to having a compressed attachment.

The internal firewall permits connection to some well known IP addresses of IBM.

*Table 1. IP addresses of IBM*

IP Address	Server Name
129.34.0.0/255.255.0.0	www-01.ibm.com
129.42.0.0/255.255.0.0	www.ibm.com
204.146.0.0/255.255.0.0	www-03.ibm.com, www-304.ibm.com
207.25.253.0/255.255.255.0	techsupport, testcase.boulder.ibm.com

When using the ECC client for reporting problem, these additional IP addresses are accessed.

**Note:** While there are no plans to change these IP addresses, the following IP addresses may be subject to change over time. The ECC Client will automatically detect changes in these service machine IP addresses, but your external firewall may need to be updated as well should any of them change.

*Table 2. IP addresses for ECC Client reporting*

IP Address	Server Name
129.35.224.103	delivery03-bld.dhe.ibm.com
129.35.224.104	delivery04-bld.dhe.ibm.com
129.35.224.105	delivery04.dhe.ibm.com
129.35.224.107	download4.boulder.ibm.com
129.35.224.108	dsw-blddhe.ibm.com.
129.35.224.109	dsw-mul.dhe.ibm.com
129.35.224.110	dsw.dhe.ibm.com
129.35.224.113	delivery03-mul.dhe.ibm.com
129.35.224.114	download3.mul.ie.ibm.com
129.35.224.115	delivery04-mul.dhe.ibm.com
129.35.224.124	dsw.mul.ie.ibm.com

Table 2. IP addresses for ECC Client reporting (continued)

IP Address	Server Name
129.42.160.51	eccgw02.rochester.ibm.com
129.42.26.224	www-945.ibm.com
129.42.34.224	www-945.ibm.com
129.42.42.224	www-945.ibm.com
170.225.15.103	delivery03-bld.dhe.ibm.com
170.225.15.104	delivery04-bld.dhe.ibm.com
170.225.15.105	delivery04.dhe.ibm.com
170.225.15.107	download4.boulder.ibm.com
170.225.15.108	dsw-bld.dhe.ibm.com
170.225.15.109	dsw-mul.dhe.ibm.com
170.225.15.110	dsw.dhe.ibm.com
170.225.15.113	delivery03-mul.dhe.ibm.com
170.225.15.115	delivery04-mul.dhe.ibm.com
170.225.15.124	dsw.boulder.ibm.com
170.225.15.28	download2.boulder.ibm.com
170.225.15.41	www6.software.ibm.com
170.225.15.76	download3.boulder.ibm.com
192.109.81.20	www.ecurep.ibm.com
207.25.252.197	eccgw01.boulder.ibm.com

## Local management via SSH

A local keyboard/mouse/monitor attached to the RSM for Storage server is required to perform initial setup and service tasks. You can perform most management tasks that require root access using an SSH session from inside your network.

Because RSM for Storage also provides the capability for Remote Access by IBM Service using SSH, RSM for Storage manages two separate SSH daemons for these two purposes. This allows the SSH port used for local management to be active all of the time, while the one used for remote connections can be turned on and off under control of the Remote Access state of the RSM for Storage software.

You must assign a different port to each daemon. The security features related to these daemons and assignment of the port to be used for local SSH management is described in Chapter 6, "Using RSM for Storage," on page 33.

## Optional external SSH connection

Instead of using a modem for external access to the RSM for Storage system, you can allow remote access by an external SSH connection. To do this you will need to map a port on your external firewall to the IP address and SSH port (typically 22, but this can be configured) on the RSM for Storage system. While the RSM for Storage system has several layers of login protection on the SSH port, you can also require firewall authentication (typically using a browser), before the external firewall makes a connection to the RSM for Storage system.



The Connections configuration page allows you to specify the external firewall IP address and port to be used by IBM Service, and an optional user ID and password to be used for authentication.

If your firewall configuration requires the external IP addresses used to make these connections, refer to the *RSM for Storage - Installation Hints and Tips* document for the most recent information. This document is available at [www.ibm.com/storage/disk/rsm](http://www.ibm.com/storage/disk/rsm).

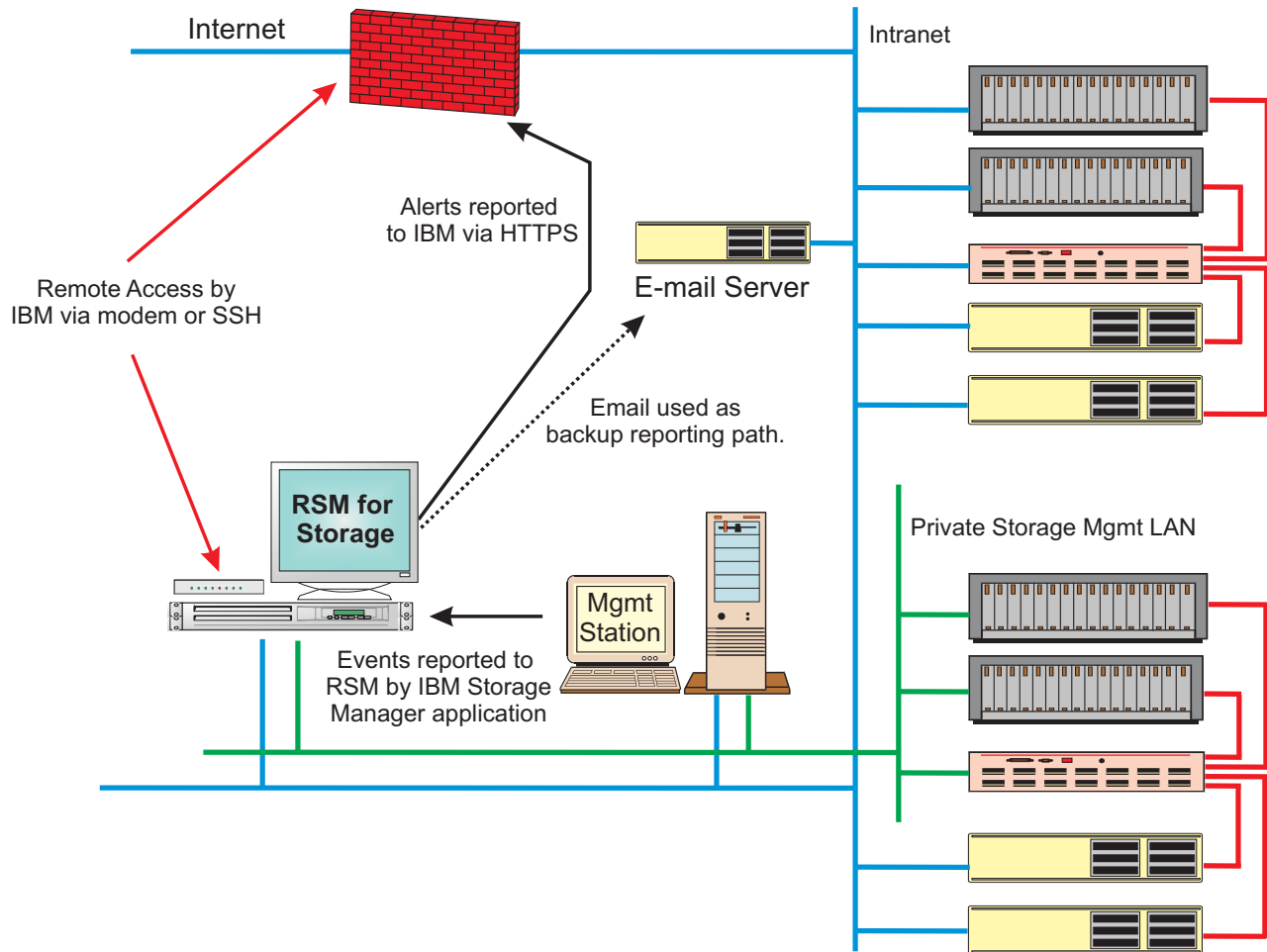

Figure 1. Network connection topology

## Ports used by RSM for Storage

**Note:** Check the RSM for Storage - Installation Hints and Tips document for the most current information regarding IP addresses and Ports used by RSM for Storage. This document is available on-line on the download page at [www.ibm.com/storage/disk/rsm](http://www.ibm.com/storage/disk/rsm)

## TCP Ports

### INPUT

The internal firewall allows no inbound connections except for the following:

*nn* SSHD

where *nn* is the port number (default is port 22)

- This port is used to provide remote access to the RSM for Storage system for IBM Support. It is enabled when the RSM for Storage's Remote Access state is enabled and the SSH configuration has been provided. A second SSH port which may be used for remote access can be configured to use a non-standard port number. See "Customizing the firewall" on page 46.

162 SNMP - Traps from IBM Storage Manager's Event Monitor

443 HTTPS - Management of the RSM for Storage from within the customer network.

## OUTPUT

The internal firewall permits outbound connections on any TCP port, but limits those connections to only devices listed in the RSM for Storage configuration and under specific conditions, such as when a device is reporting a problem. The following ports are routinely used by RSM for Storage:

21 FTP - Used by ECC to update tables of IBM ECC Server IP addresses.

25 SMTP - Used by RSM for Storage software to send alerts and notifications.

53 DNS - Used by Linux mail transfer agent while sending e-mail notifications.

80 HTTP - Used by IBM's Electronic Customer Care (ECC) client for initial access to IBM servers.

443 HTTPS - Used by ECC client for secure transmission of status and problem reports.

2463 SMcli - Used by RSM for Storage software to access the storage subsystem status

The TELNET and RLOGIN protocols are not used by the RSM for Storage software, but may be used by IBM Support to connect to the storage controllers for resolution of complex problems. Which protocol may be needed depends on the level of controller firmware on the storage subsystem.

23 TELNET

513 RLOGIN

The following port number is the destination port typically used by various client applications. It may be useful for a local or remote user of the RSM for Storage system in some situations. This port is not currently used by the RSM for Storage software, but may be included in future enhancements.

22 SSH

## Allowed ICMP types

Table 3 shows the allowed ICMP types.

Table 3. Allowed ICMP types

INPUT	OUTPUT
echo-request	echo-request
echo-reply	echo-reply
time-exceeded	

Table 3. Allowed ICMP types (continued)

INPUT	OUTPUT
destination-unreachable	
<p><b>Note:</b> If your network blocks the use of PING, you can disable it's use by RSM for Storage for verifying connectivity. The option for this is one of the "Options" on the System Configuration management page.</p>	

## Preparing for installation

- Choose a server that meets the minimum requirements. See the *RSM for Storage Compatibility Guide* for more information.
- Obtain a supported Linux operating system. See the *RSM for Storage Compatibility Guide* for more information.

If using a modem to provide remote access:

- Choose a modem. See the *RSM for Storage Compatibility Guide* for more information.

Your modem may be supplied with a RJ-11 phone cord. You may need to supply an adapter in order to connect the RJ-11 phone cord to your phone system.

## Site Preparation

### Remote Access

If you are using a modem to provide remote access, arrange for an analog phone line connection.

If you are using an SSH connection to provide remote access, plan the details of the port mapping and firewall authentication required to support the connection.

### Local Access

You will need a keyboard, mouse and monitor attached to the RSM for Storage server for installation and troubleshooting.

## Information you will need

To successfully install and configure RSM for Storage, you will need to gather various types of information including the following:

- Network setup information for the RSM for Storage server
- Company information and contact details
- Connection information
- Information on the storage subsystems to be monitored

Appendix E, "Planning worksheets," on page 77 provides detailed worksheets to help you gather the information needed to successfully install and configure RSM for Storage.

### Information used during the installation of the operating system

The following network setup information will be used during the installation of the Linux OS. Use "Worksheet #1: Network setup information for the RSM for Storage server" on page 77 to record this information.

- Time zone where the RSM for Storage system will be located
- Root user password
- Hostname for the server (ibmrsm is suggested)

- Your company's domain name
- IP addresses of your domain name servers
 

It is recommended that you use static IP addresses for all network resources and management systems. The RSM for Storage system and the storage subsystems monitored by it must have static IP addresses.
- Static IP address to be assigned to the server
- Netmask for the server
- Gateway IP address

If a second Ethernet connection is required to reach the Internet and your SMTP server, you will need the information above for this port as well.

### **Information used during configuration of RSM for Storage**

In addition to your company name and address, you will need to configure contact people, connection information for the RSM for Storage system, and each storage system to be monitored.

**Contact people:** At least one contact person must be defined as the primary contact for the RSM for Storage system. If you wish to have more than one person receive these e-mails, consider creating a special e-mail account for RSM notifications that will then forward to your extended contact list.

If your storage subsystems are not physically located at the same location as the RSM for Storage system, you must define additional contacts for each different location. The following information is needed when configuring contact people:

- Name and e-mail address
- Primary phone number and the hours to call this number
- Alternate phone number and the hours to call this number
- Time zone

Use “Worksheet #4: Contact people” on page 79 to gather the necessary information to configure contact people.

**Connection information for the RSM for Storage system:** You will need to gather the following information to configure the connection for RSM for Storage system:

- IP address of your company's e-mail (SMTP) server
- Location of the server
- Address, city, state, and postal code
- Country or region
- Phone number for the modem
- IP address and port on your external firewall for the remote SSH connection.
- If authentication through a Web browser is required before the SSH connection can be made, you can specify the user ID and password to be used for authentication.

Use “Worksheet #3: Connection information for the RSM for Storage system” on page 78 to gather the appropriate information needed to successfully configure the connection for the RSM for Storage system.

**Information for each storage subsystem to be monitored:** Gather the following information for the storage subsystems that will be monitored by RSM for Storage:

- Storage subsystem name

**Note:** This must be the same name used to identify the subsystem in IBM DS Storage Manager.

- Static IP address of the controllers in each subsystem
- Location of subsystem
- Address, city state, postal code
- Country or region
- Contact person for this subsystem  
(One of the previously configured contacts)
- IBM machine type, model and serial number
- Phone number for the storage subsystem site

This phone number must ring at the site where the storage subsystem is located. For service in the United States and Canada, this number is used to determine the nearest IBM location from which service will be dispatched. This number can be different from the contact phone numbers that are already configured.

- Ensure that the storage subsystem is covered under warranty or a current IBM maintenance agreement.

**Note:** Use “Worksheet #5: Information for each Storage Subsystem” on page 80 to gather the appropriate information needed to successfully configure the subsystems to be monitored by RSM for Storage.

For each drive expansion unit you will need the following:

- The IBM machine and serial number
- The expansion unit ID number as shown in IBM DS Storage Manager

**Information for other SAN devices:** Additional devices such as SAN switches can be configured to be accessible from the RSM for Storage system. The RSM for Storage software will not monitor these for problems, but the system can be used to provide remote access for problem resolution if necessary.

Only the host name and IP address of each device are required. Use “Worksheet #6: Information for other SAN devices to be accessible from the RSM for Storage system” on page 82 to gather the appropriate information for additional devices.



---

## Chapter 2. Installation overview

This chapter provides detailed instructions for installing the hardware and software necessary for using RSM for Storage, instructions for verifying connectivity and details for configuring RSM for Storage.

**Note:** Please refer to the *RSM for Storage - Hints and Tips* document for recent updates or corrections to this manual. The *Hints and Tips* document is available at [www.ibm.com/storage/disk/rsm](http://www.ibm.com/storage/disk/rsm).

---

### Hardware installation

Use the following sections to install the appropriate hardware necessary for RSM for Storage to work in your environment.

### VMware environments

RSM for Storage has been tested for operation in a VMware virtual client.

Installation in a VMware environment is intended for users that have prior experience with setup and configuration of VMware systems. RSM for Storage Support cannot provide assistance with installation, setup or configuration of a VMware environment beyond what is described here.

#### Virtual Client configuration

In setting up the virtual client allocate the following resources:

- Storage: 20 GB
- Memory 512 MB
- Assign exclusive physical ownership of the host system's first serial port to the virtual client as `/dev/ttyS0`

The client must be configured to automatically start when the host reboots.

#### RSM for Storage configuration

Two additional fields must be provided in the RSM for Storage configuration pages.

When a VMware environment is detected by the RSM for Storage software, you will be prompted to enter the IBM machine type and serial number of the hosting system on the RSM for Storage Connections configuration page.

The IBM server type and serial number are required in order to properly register heartbeat records from the RSM for Storage system in IBM tracking databases.

### Servers

1. Install the server using the setup instructions that came with the server.
2. Connect one Ethernet cable from the server to an Ethernet switch or hub providing connection to your SAN Management LAN.
3. If the Internet and your company's e-mail (SMTP) server are not accessible from your SAN Management LAN, connect a second Ethernet cable from the server to the Ethernet switch or hub providing connection to the Internet and e-mail server.

## Updating the server firmware

1. Go to: <http://www.ibm.com/support>:
  - Under **Support by product**, click **Servers**.
  - Under **Product Support**, click **System x**.
  - Under **Popular Links**, click **Software and device drivers**.
  - Click your system type.
2. If you are using one of the servers that has been tested with RSM for Storage, refer to the *RSM for Storage – Installation Hints and Tip* document for additional information.
3. Note that to update the firmware before loading an operating system, you should download the DOS versions of the updates. Also, on the individual firmware pages, look for the link: **New firmware update file formats**. This page explains how to create the media for each of the available file formats for the update.
4. When the prompt, Press F1 for Configuration/Setup is displayed, press **F1**.
  - Select **Load Default Settings** and press **Enter**.
  - Select **Save Settings**.
  - Exit BIOS Setup and reboot the system.

## Modem

Install the modem using the setup instructions that came with the modem, and then do the following:

1. Connect the serial cable from the modem to the first serial port on the server. Figure 2 shows you how to make this connection.

**Note:** If your server has two server ports, port #1 is typically the one next to the keyboard connector.

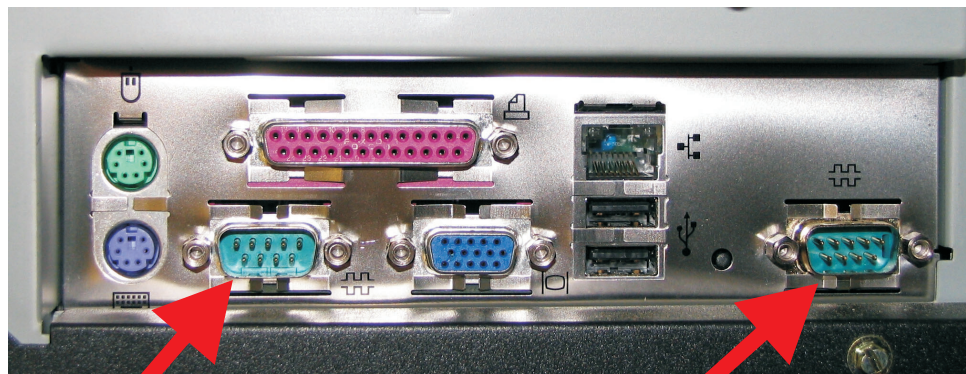

Figure 2. Serial port connection

2. Connect an analog phone line to the proper connector on the modem. Note that many modems have two connectors labeled LINE and PHONE. Make sure the analog phone cord is plugged into the connector labeled LINE.



---

## Software installation

If you are using the DS-RSM server, it is already loaded with the Linux OS and an initial version of RSM for Storage software that is ready to install. No additional preparation is necessary. Continue with Chapter 3, “Installing RSM for Storage,” on page 17.

If you are not using the DS-RSM server, this section provides instructions for installing the Linux operating system, RSM for Storage, and updates to RSM for Storage. Before you begin installing the operating system, you will need to gather network setup information for the RSM for Storage server. See Appendix E, “Planning worksheets,” on page 77.

RSM for Storage software is designed to install on the standard Linux distributions listed in the *RSM for Storage Configuration Guide* and with the configuration specified in the installation chapter of this document. Installation or activation of programs, services or software not specifically listed in this document may not work as expected, or may interfere with the operation of RSM for Storage.

Appendix B, “Installing the SLES 10 operating system,” on page 63 contains instructions for installing the SLES 10 operating system.

Appendix A, “Installing the SLES 11 operating system,” on page 57 contains instructions for installing the SLES 11 operating system.

Appendix C, “Installing the RHEL 4 AS, Update 4 or Update 5 operating system,” on page 69 contains instructions for installing the Red Hat RHEL 4 operating system.

Appendix D, “Installing the RHEL 5 operating system,” on page 73 contains instructions for installing the RHEL 5 operating system.

After installing the Linux OS, continue with Chapter 3, “Installing RSM for Storage,” on page 17.



---

## Chapter 3. Installing RSM for Storage

---

### Starting the installation from a CD

**Note:** Please refer to the 'Special instructions for installing the Mutt e-mail agent' section of the *RSM for Storage - Hints and Tips* document. The *Hints and Tips* document is available at [www.ibm.com/storage/disk/rsm](http://www.ibm.com/storage/disk/rsm).

To install RSM for Storage from a CD, complete the following steps:

1. Log in to the server as root.
2. Insert the Remote Support Manager for Storage CD into the CD-ROM drive, and continue with one of the following:

If a window opens that displays the contents of the CD-ROM	<ol style="list-style-type: none"><li>1. Right-click on the file autorun.sh.</li><li>2. If Open With -&gt; Bash is available, click on Bash. Otherwise select <b>Open With -&gt; Other...</b> and type bash in the Open With field.</li><li>3. Click <b>OK</b>.</li><li>4. Go to step 3.</li></ol>
If a window opens indicating that a new medium has been detected	<ol style="list-style-type: none"><li>1. Check <b>Always for this type of media</b>, and click <b>OK</b>.</li><li>2. Right-click on the file autorun.sh.</li><li>3. Click <b>Open With -&gt; Other...</b></li><li>4. Type /bin/bash in the "Open with" field at the top of the window.</li><li>5. Click <b>OK</b>.</li><li>6. Go to step 3.</li></ol>
If a CD-ROM icon is present on the desktop	<ol style="list-style-type: none"><li>1. Right-click on the CD-ROM icon and select <b>Mount</b>.</li><li>2. Right-click on the file autorun.sh.</li><li>3. If Open With -&gt; Bash is available, click on <b>Bash</b>. Otherwise select <b>Open With -&gt; Other....</b> and type bash in the Open With field.</li><li>4. Click <b>OK</b>.</li><li>5. Go to step 3.</li></ol>
If an Autorun dialog box displays asking you if you want to run the script	<ol style="list-style-type: none"><li>1. Click <b>Yes</b> to install RSM for Storage.</li><li>2. Go to step 3.</li></ol>

3. When the RSM for Storage installation window opens, enter Install to start the installation script.
4. Continue with "Installation steps."

---

### Installation steps

**Note:** If you are installing RSM for Storage software using an SSH connection inside your network, check that X11 support is enabled and working. If problems are detected in any of the Linux networking configuration setting during setup, the RSM for Storage setup program will automatically open the proper Linux Networking setup GUI to evaluate or repair the problem.

1. Before the installation starts to install the RSM for Storage software, a number of checks are made to verify that the server has the proper configuration. If a

problem is found with one of these, the installation will pause and prompt you to correct the problem. In some cases the appropriate panel from the Linux Operating System's Configuration program will be launched so you can correct the problem without leaving the RSM installation program.

If no problems are found, the installation will quickly continue to install the RSM software. The following checks will be performed:

- That the required Linux packages were selected during the Linux OS installation.
- Verify that the Linux Network configuration is complete. This includes:
  - Host name and domain name of the server
  - IP address and netmask of the server
  - Gateway address
  - At least one DNS server

Also during these checks, attempts will be made to reach [www.ibm.com](http://www.ibm.com) on the internet. If after verifying the correct values have been entered, internet access still can not be verified, it may be that network does not allow access to the internet or requires a proxy server. In this case, you will need to ignore the warning message and continue with the installation. There are other RSM for Storage configuration options that you will be able to specify later that may allow RSM for Storage to work in this network environment.

**Note:** On Red Hat installations a common mistake during the installation of the operating system is to put only the hostname in the Linux networking setup and leave out your company's domain name. This will be detected during the first part of the RSM for Storage installation and you will be prompted to fix it.

When the pop-up panel appears, enter the complete hostname such as: `rsm01.your_company.com`

On the Hosts tab, first select 'New'. Enter the IP Address, Hostname (`rsm-01.yourcompany.com`) and any aliases for the system. Select **File** -> **Save** and click **OK** to close the pop up. See Figure 3 on page 19.

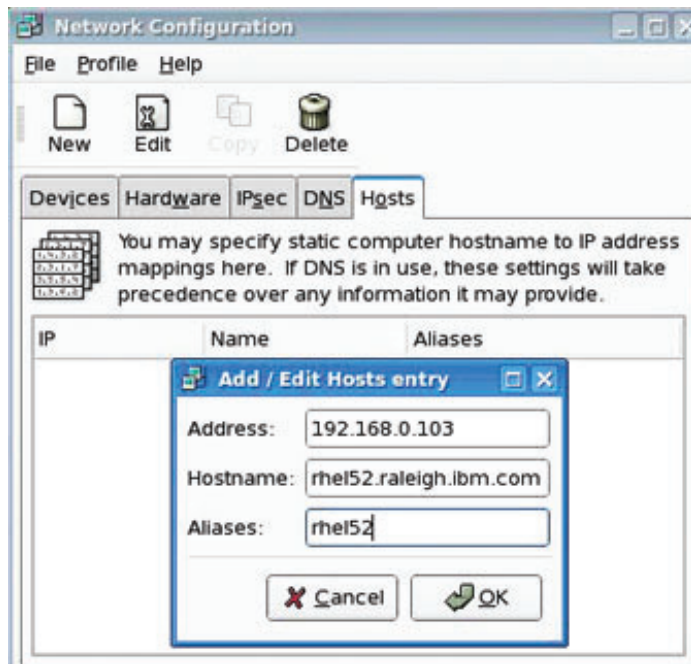

Figure 3. Network Configuration

- Network connectivity is tested by attempting connections to the following:
  - HTTP to www.ibm.com
  - Ping the IP address of your SMTP email server (which you will be prompted for)
  - Ping the IP address of a device on your storage management LAN, such as the management station running IBM DS Storage Manager. (You will be prompted for this address.)
- If this is the first installation of RSM for Storage, e-mail delivery is verified. RSM for Storage sends log files as compressed attachments to e-mails, the ability for your e-mail server/filter to deliver these attachments is important for prompt resolution of problems. E-mail delivery is verified by sending test e-mails to two addresses which you will be prompted for:
  - An e-mail address inside your network
  - An e-mail address outside your network

RSM for Storage will attempt to send these e-mails directly to the destination. If all of these e-mails do not arrive, there are several options available to resolve the problem.

To continue to have RSM for Storage send e-mails directly, your IT staff may need to change the configuration of your external firewall to allow outbound e-mail traffic on port 25 from the RSM for Storage system.

You will also have the option to have RSM for Storage relay mail through your SMTP e-mail server and run the e-mail test again. If all of these e-mails do not arrive, your IT staff may need to do the following:

- a. Configure your firewall to allow the RSM for Storage system to send e-mail directly to their destination.
- b. Configure your e-mail server to allow forwarding of mail from the RSM for Storage system.
- c. Configure your e-mail filter to allow sending of e-mails from the RSM for Storage system that have ZIP file attachments.

While you have the option to ignore Email delivery problems and continue with the setup, you should resolve the Email delivery problem before continuing. In order for IBM to assist you with resolving other setup or configuration problems, they will need to obtain a dump file that can best be sent from the RSM system using Email.

2. After the RSM for Storage package files are installed you will be prompted to set the passwords for the two predefined users: admin and lservice (unless this is an upgrade of RSM for Storage software).

The Linux system password for these users is set with the command: **passwd user\_name**.

- Type `passwd admin` to set the Linux password for the admin user. This is the user and password that will be used to configure and manage the Remote Support Manager.
- Type `passwd lservice` to set the Linux password for the lservice user. This is the user and password that can be used locally by IBM Service. This user cannot configure or change any of the security aspects of the Remote Support Manager. It can be used to view, acknowledge and close alerts.

The passwords for the RSM for Storage browser interface are set with the command **rsm-passwd user\_name**.

- Type `rsm-passwd admin` to set the password for the admin user.
- Type `rsm-passwd lservice` to set the password for the lservice account for use by IBM onsite service.

3. Exit the RSM for Storage Installation window.
4. Log out of the root user session by clicking the icon in the lower left of the status bar
5. On the login screen, do the following:
  - a. Click on **Session** and select **KDE**.
  - b. Log in as the lservice user.
  - c. Let the desktop do its first time initialization.
  - d. Open a terminal console window. This adds the RSM for Storage icons to the desktop. The next time lservice user logs in, the background appearance will be changed to an RSM for Storage background.
  - e. Log out as the lservice user.
6. On the login screen, do the following:
  - a. Click on **Session** and select **KDE**.
  - b. Log in as the admin user.
  - c. Let the desktop do its first time initialization.
  - d. Open a terminal console window, then close the window. New icons have been placed on the desktop to facilitate management of RSM for Storage. The next time the admin user logs in, the background appearance will be changed to a RSM for Storage background.

**Note:** You should always log in to the server running the RSM for Storage as the admin user. The root user account should only be used for system maintenance and upgrades.

7. Continue with Chapter 4, "Configuration," on page 21.

---

## Chapter 4. Configuration

**Note:** Please refer to the *RSM for Storage - Hints and Tips* document for recent updates or corrections to this manual. The *Hints and Tips* document is available at [www.ibm.com/storage/disk/rsm](http://www.ibm.com/storage/disk/rsm).

This section provides detailed configuration information for the following:

- “Configuring RSM for Storage”
- “IBM DS Storage Manager” on page 23
- “Modem connectivity” on page 25
- “Verify Remote Access connectivity” on page 24

---

### Configuring RSM for Storage

To configure RSM for Storage, do the following:

**Note:** Appendix E, “Planning worksheets,” on page 77 can help you get through this configuration process.

1. Launch the RSM for Storage user interface by clicking the **Manage** icon on the desktop.
2. If this is the first time you have started the browser, the summary status will be Configuration Incomplete.
3. Log in to the RSM for Storage browser interface as admin.
4. Select **Update Configuration** and then provide the requested information for the following configuration areas:
  - a. **Contacts** - You need to define at least one contact person, but may define up to 20 people. One of these contacts must be defined as the Primary Contact for the RSM for Storage system. Often this person is the same contact for your storage subsystems.

If you have storage subsystems at different locations, you should also define a contact person for each of those locations. Later during configuration of the storage subsystems, you will be able to associate one of the contacts defined here with each storage subsystem. Alerts sent to IBM include, the primary contact information for the RSM for Storage server and the information for the contact associated with the subsystem reporting a problem.

Only one of these contact entires can be associated with a given subsystem. You can use the "alternate phone number" and "hours to call" fields to specify another person for IBM Service to call in case the first person is not available. The phone number fields can only contain the number. But the "Hours to Call" fields are free form and you can put any text into them as shown in the following example:

**Who should IBM Support contact:**

Joe Smith	Contact person
smithj@company.com	E-mail address
123-5551234	Phone number
9-5 - From 5 to 9pm call 123-555-9991	Hours to call or other information (see Help)
US Eastern	Time Zone
(123) 444-5678	Alternate phone number (optional)
Operations Desk - call if Joe Smith not available	Hours to call or other information for alternate number (optional)
<input type="checkbox"/> Make this person the primary contact for the RSM for Storage system	
United States	Country or region
<a href="#">Update configuration</a>	

b. Company

c. Options - If your system does not allow Remote Access, enable 'One-Way Call Home' here and refer to "Enabling One-way Call Home" on page 47 for more information.

d. Connections

e. Storage

If you have a large number of storage subsystems that have the same contact and location information, you can use the **Copy Form** button on a configuration page for one subsystem to make a copy. This will eliminate the need to re-enter much of the configuration information.

f. Switches

For additional information about any of the configuration fields, click on the help link in the upper right of each page.

Appendix E, "Planning worksheets," on page 77 is provided to help you fill in the required information for these areas.

If any information is missing or appears to be incorrectly formatted, a status of Incomplete will be shown and the specific field on that page that is incomplete will be flagged with an asterisk. Click on the help link for suggestions on how to correct the problem.

**Note:** Configuration of drive expansion units is also required but will not be performed until after the Configuration Test (described in the next step) is performed.

5. When each configuration section shows a status of OK, an option to run a Configuration Test will be available at the bottom of the screen.

The RSM for Storage Configuration Test will verify connectivity to all configured devices. Click **Refresh Status** until the test completes and the results are shown. Any problems are indicated by a status of Problem and the specific device will be flagged with a double asterisk. Click on the areas indicating a problem to determine which device and/or IP address could not be reached. Additional information about test results are written to the Activity Log and displayed on the System Configuration page. Refer to the Help for the Configuration page for suggestions on resolving the problem.

Re-run the configuration test until all problems are resolved.

6. During the configuration test, the profile for each subsystem will be downloaded. This will verify connectivity to the subsystem, verify that this version of RSM for Storage software is compatible with the firmware on the subsystem and if the subsystem name matches the name used in DS Storage Manager. The configuration test will also determine if there are any drive expansion units attached to the controller. If any drive expansion units are detected, the



configuration status for the subsystem will change to Configuration Incomplete and additional configuration fields will now be available for setting the IBM machine type and serial numbers of each detected drive expansion unit.

7. The configuration Test can not verify that the IBM Machine Types (Product ID) and Serial numbers have been entered correctly. Errors for these values will result in problem report failing checks for service entitlement when they reach IBM. So help you verify this important information, there is a button near the bottom of the Configuration Management page that will export these values to and CSV file, which be then be opened using a spreadsheet program.

This will allow you to more quickly verify the entered values against the labels on the systems or asset listings for your hardware systems.

---

## IBM DS Storage Manager

This section defines the configuration changes you must make to IBM PS Storage Manager when attaching RSM for Storage to a DS3000, DS4000 or DS5000 product or a mix of all three products.

**Note:** These changes must be made in IBM DS Storage Manager running on your management station, not on the RSM for Storage system.

### Turn off automatic collection of support data

To turn off automatic collection of support data, do the following:

1. On the Subsystem Management window for each subsystem, select **Advanced ->Troubleshooting ->Automatic Support Data Collection**.
2. Uncheck the box **Automatically collect support data for critical events**. This is not required as RSM for Storage will collect this support data.
3. Repeat this for each storage subsystem.

### Configure SNMP traps to be sent to the Remote Support Manager

The RSM for Storage system sends alerts to IBM Service when SNMP traps with event information are received from the subsystems being monitored. SNMP traps are sent by the IBM DS Storage Manager client and/or the IBM DS Storage Manager's Event Monitor service. As the DS Storage Manager Client may not always be running, it is recommended that the Event Monitor be installed and configured to start automatically.

**Note:** The Event Manager is installed during the installation of the IBM DS Storage Manager. For information about determining whether Event Manager is installed, refer to the documentation that came with your subsystem.

To send traps to the RSM for Storage system, configure the RSM for Storage system as a destination for SNMP traps in the IBM DS Storage Manager client. This configuration will also be applied to the Event Monitor (if installed) on that same system.

**Note:** The following procedure assumes that all subsystems managed by the IBM DS Storage Manager will be configured for reporting in the RSM for Storage software. If this is not the case, configure individual subsystems in step 2 below. Do not configure any subsystem that is not covered by warranty or a current maintenance contract.

1. Select **Task Assistant** from the View menu pull-down.
2. Click the **Configure Alerts** button.

3. Select **All storage subsystems**, and then click **OK**.
4. Select the **SNMP** tab.
5. Enter the IP address of the RSM for Storage system in the Trap Destination window.
6. Click **Add**.
7. Click **Validate** to send a test trap the RSM for Storage system.

The RSM for Storage software ignores test alerts such as these, but you can verify that it was received by viewing the RSM for Storage Activity Log. Click on the magnifying glass icon on the desktop labeled Activity Log. The reception of the test alert and the fact that it was ignored should be logged.

**Note:** After installing updates to IBM DS Storage Manager, verify that the SNMP trap configuration is still set up to send traps to the RSM for Storage subsystem.

### **DS Storage Manager passwords**

DS Storage Manager has a privileged mode of operation. If a password has been entered for the admin user, then any attempt to change the configuration of the subsystem will require the admin password. It is recommended that the admin password be set. If you choose to have IBM Service make configuration changes for you, you will need to provide them with the admin password or disable it for the duration of the service action.

### **Shell access Security**

DS3000, DS4000, and DS5000 subsystems provide a way to access the controller shell environment using the rlogin protocol. rlogin has limited security and is generally considered a security risk. DS Storage Manager provides a way to disable the rlogin support in the subsystems' controllers and it is generally recommended that it be disabled. If IBM Service requires access to the shell, they will need to contact you to have rlogin access enabled.

---

## **Verify Remote Access connectivity**

### **SSH connectivity**

**Note:** If you have enabled 'One-Way Call Home', Go to "Activation" on page 25.

On the RSM for Storage Remote Access page, click **Enable Remote Access**. This will reconfigure the RSM for Storage internal firewall to allow connections via the port specified for the "SSH port for RSM to listen on for remote access" in the Connections Information configuration.

Verify connectivity in the following sequence:

1. From inside your network, open an SSH client and connect to the RSM for Storage system on the port specified for the "SSH port for RSM to listen on for remote access" in the Connections Information configuration. (Remember, if you perform these connectivity checks over several days, that the RSM for Storage Remote Access control has a timeout that may need to be reset.) Verify that you are able to obtain a login prompt from the RSM for Storage system.
2. From outside your network, open an SSH client and connect to your external IP address and port (specified as "External Firewall Port IBM should use") in the Connections Information configuration.

You should be connected to the RSM for Storage system and receive a login prompt.

**Note:** You will not be able to complete the login. Authentication requires a special tool only available to IBM Remote Support.

If an authentication process has been put in place by your firewall administrator, verify that the user ID and password for the external firewall is specified in the RSM for Storage Connections configuration.

3. Verify that the SSH connection is correctly configured on the Connections Configuration page. This information will be encrypted and sent with each alert to IBM.

## Modem connectivity

### Communication between the modem and server

During configuration of the Remote Support Manager, you performed a configuration test (See “Configuring RSM for Storage” on page 21). If you configured a modem, the Configuration Test will verify that the RSM for Storage software can communicate with the modem. If the configuration test completed without errors then the modem is connected to the correct serial port and is communicating with the RSM for Storage software.

### Remote access to the modem

On the RSM for Storage Remote Access page, click **Enable Remote Access**. This will enable the modem to answer when called. Verify modem connectivity by calling the modem phone number from a voice phone.

Most modems will either flash an LED or you may hear a sound when a call is being received.

1. If there is no indication that a call is being received:
  - a. Plug the phone cable into an analog voice phone and verify that a dial tone is present.
  - b. If a dial tone is present, hang up and then call this phone number from another phone and verify that the phone you just connected rings.
  - c. Reconnect the phone cord to the modem connector labeled line #1.
2. Try again to verify the modem connectivity by calling the modem phone number from a voice phone.
3. Check the instructions that came with the modem and review any troubleshooting information.

---

## Activation

Before the Remote Support Manager for Storage will send alerts to IBM it must be activated by contacting IBM Service. This is also the last step in verifying correct operation of the RSM for Storage.

On the RSM for Storage user interface, click **Remote Access** and enable remote access.

Call the number for IBM Service for your region and give the machine type and serial number of one of the storage subsystems to be monitored by the RSM for Storage. Go to [www.ibm.com/planetwide](http://www.ibm.com/planetwide) for support telephone numbers in your country or region. When you are contacted by the disk subsystem support team, verify that you are talking with DASD Support for DS3000, DS4000, or DS5000 and

tell them you are activating an RSM for Storage system. If you have enabled 'One-Way Call Home' , inform about that and refer to “Activating when you have enabled 'One-Way Call Home'.”

Provide IBM Service with one or both of the following pieces of access information:

- The phone number of the modem attached to the RSM for Storage system.
- The IP address/port number and any required authentication information to be used for SSH access.

IBM Service will connect to the system, verify that the configuration is correct, send a test alert via e-mail, verify receipt of the alert and associated attachments and then activate the system.

You can ensure that problem reports will not be rejected because of incorrectly entered machine information by verifying your information with IBM support. Ask IBM support to verify that the machine types and serial numbers for the storage that is configured in RSM are recognized as valid by IBM entitlement systems. Ask for this same verification whenever you configure additional storage devices.

**Note:** If you decide to install the RSM for Storage software on another server, you will need to contact IBM Service to obtain a new activation key for the new server.

## Activating when you have enabled 'One-Way Call Home'

If you have enabled 'One-Way Call Home', IBM Remote Support will guide you to -

1. Log on to the RSM browser interface as lservice.
2. Click **Update System Configuration**.
3. Click **Activation**.

You must test if your system sends alerts to IBM Support successfully or not.

1. Click **Send Test Alerts** and confirm with IBM Remote Support whether the test alert is in the call queue.
2. Use the command line program 'rsm-entitle-check <email address>' to send the serial numbers of the configured systems to IBM Remote Support. IBM Remote Support provides the email address for this command line program. You can activate RSM for Storage System once IBM Remote Support confirms the serial number.
3. Provide your Activation ID comprising letters and numbers to IBM Remote Support. Use the same command line program 'rsm-entitle-check <email address>' to send the Activation ID. IBM Remote Support upon verifying the Activation ID, provides you with an Activation key.
4. Enter this Activation key, the overall system status will be OK if all other configuration errors are resolved.

**Note:** If IBM Remote Support fails to receive your test alert, it could be due to an issue with your firewall. Resolve this issue and send another test alert.

When the RSM for Storage system is ready to receive events, the System Status will be OK.

# IBM Remote Support Manager for Storage

[Login](#) - [Refresh status](#) - [Help](#)

---

## Main Menu

[System:](#) OK                      [Firewall:](#)                      **Enabled: Custom**  
[Reporting:](#) All Subsystems      [Remote Access:](#) Disabled

[Update](#) System Configuration  
[Manage](#) Reporting and Alerts  
[Manage](#) Internal Firewall  
[Manage](#) Remote Access  
[View](#) Statistics and Logs

*Need Help?*  
[Troubleshooting Problems](#)  
[Calling for Service or Support](#)

---

Version: 2.1.1\_CMVC\_SB\_p211ecc\_09\_09\_21\_17\_21 - Sep 21 2009 17:21:29

[Login](#) - [Refresh status](#) - [Help](#)

*Figure 4. Example of a configured system*

You can leave the browser session running, but you will need to select **Refresh status** to see changes in status.

**Note:** After 10 minutes of no activity on the user interface, you will be prompted to log in again.

---

## Backing up your configuration

After your RSM system is operational, take a few minutes to make a backup copy of your configuration file and store it on another system.

See “Saving and restoring configuration files” on page 40.



---

## Chapter 5. Installing updates to RSM for Storage

### Notes:

1. Please refer to the *RSM for Storage - Hints and Tips* document for recent updates or corrections to this manual. The *Hints and Tips* document is available at [www.ibm.com/storage/disk/rsm](http://www.ibm.com/storage/disk/rsm).
2. When performing updates to the Storage Manager Client, it is recommended to update the Remote Support Manager software first.

Updates to the Remote Support Manager software will be distributed as a CD Image file (.iso) or as a compressed (.zip) file. You can burn a CD from the ISO file or you can download the ZIP file directly to the RSM for Storage server. All configuration files will be preserved during the update process. Some updates may require that additional configuration details be provided after the update. If additional configuration information is required for the update, the System status will be Incomplete and you need to supply the new information before the RSM for Storage system will send alerts to IBM.

Open a Web browser and go to <http://www.ibm.com/servers/storage/disk/rsm>. The download page will contain the following files:

**ibm\_sw\_ds4krsm\_x.x.xx\_linux\_32-64.zip** – Download directly in the /packages directory on the RSM server

**ibm\_sw\_ds4krsm\_x.x.xx\_linux\_32-64.iso** – Burn to a CD-ROM

**ibm\_sw\_ds4krsm\_x.x.xx\_linux\_32-64.txt** – The README file contains specific information about this new version

**ibm\_sw\_ds4krsm\_x.x.xx\_linux\_32-64.chg** – The Change History file explains the new function problems fixed in this version

If new configuration information is not required, all previously configured information should be present and the RSM for Storage system should be operational.

You can expect to update your RSM for Storage software each time a new version of controller firmware is installed on your storage subsystems.

**Note:** After updating the IBM Storage Manager client on your management station to a new version, verify that the RSM for Storage system is still configured to receive SNMP event traps.

---

### Updating the RSM for Storage using a ZIP file

Log in to the Remote Support Manager server as the “root” user.

The download site may be accessible by the RSM for Storage system without needing to disable the RSM for Storage internal firewall. IBM’s external server and Web site links do sometimes change however, and if the site can not be reached, you will need to disable the RSM for Storage firewall during the download.

Open a Web browser and go to <http://www.ibm.com/storage/disk/rsm> for instructions to download software and documentation.

The .txt file contains specific instructions for installing the update. The .chg file contains details about the changes made in this and previous versions.

1. Download the .zip file into the /packages directory on the RSM system.

2. If there is an icon on the desktop named **RSM Update**, click on this icon to select a version of RSM for Storage to install. Otherwise continue with Step 3.
3. Open a console window and type the following into the window.

**Note:** x.x.xx is the version number of the RSM software you just downloaded.

```
cd /packages
unzip ibm_sw_ds4krsm_x.x.xx_linux_32-64.zip
cd /packages/rsm-x.x.xx
./rsm-setup
```

Launch the Remote Support Manager user interface by clicking on the icon labeled **Manage** on the desktop.

If additional configuration information is required for the update, the System status will be Incomplete and you will need to supply the new information. All previously entered configuration information should be present and the Remote Support Manager should be operational. Refer to the `readme.txt` and `changes.txt` files in the `/packages/rsm-x.x.xx` directory for more information.

---

## Updating RSM for Storage using a CD-ROM

The CD-ROM image can be downloaded from <http://www.ibm.com/servers/storage/disk/rsm>.

The `.txt` file contains specific instructions for installing the update. The `.chg` file contains details about the changes made in this and previous versions. Download the `.ISO` file and burn a CD, and do the following:

1. Log in to the Remote Support Manager server as the `root` user.
2. Close all open windows on the desktop.
3. Insert the RSM for Storage CD into the CD-ROM drive, and do the following:
  - For **SLES 11**:
    - a. Click the File Cabinet icon in the system tray to open the Dolphin file manager.
    - b. Click the **RSM for Storage** CD-ROM icon.
    - c. Click the **autorun.sh** file to start the RSM for Storage installation.
  - For **SLES 10**:
    - a. In a few seconds, the OS should recognize the CD and a prompt to run the program will appear.
    - b. Click **Yes** to start the `autorun` file.
  - For **RHEL 4** and **RHEL 5**:
    - a. Right click on the CD-ROM icon on the desktop and select **Mount**.
    - b. Double-click the CD-ROM icon on the desktop. The contents of the CD should be displayed.
    - c. Double-click on the **autorun.sh** file to start the RSM for Storage installation.
4. When the installation is complete, remove the CD from the drive.
5. Launch the Remote Support Manager user interface by clicking on the icon labeled **Manage** on the desktop.

If additional configuration information is required for the update, the system status will be Incomplete and you will need to supply the new information. All previously entered configuration information should be present and the Remote Support



Manger should be operational. Refer to the readme.txt and changes.txt files in the /packages/rsm-x.x.xx directory for more information.



---

## Chapter 6. Using RSM for Storage

This chapter provides an overview of the RSM for Storage programs, details on the different types of users for RSM for Storage, and information about managing the RSM for Storage software.

**Note:** Please refer to the *RSM for Storage - Hints and Tips* document for recent updates or corrections to this manual. The *Hints and Tips* document is available at [www.ibm.com/storage/disk/rsm](http://www.ibm.com/storage/disk/rsm).

---

### User IDs and desktops

During installation, the RSM for Storage software creates three user IDs:

**admin** This is the Administrative user that can perform management and configuration tasks.

**lservice**

This is the Local Service user intended for use by IBM Service when on-site.

**rservice**

This is the Remote Service user that is used exclusively for remote access to the system.

The local desktops for the admin and lservice users are setup with different backgrounds so you can easily tell which user is logged into the RSM for Storage system. The lservice user has some restrictions on directories it can access that prevent it from changing any configuration that might affect security of the system.

---

### Icons

The desktop has four icons to launch RSM for Storage programs.

**Manage**

Starts a Web browser and opens the management page for RSM for Storage.

**Help**

Starts a Web browser and opens the master help page.

**Activity Log**

Opens a console window and displays the most recent entries in the Activity Log. The Activity Log contains time stamped entries for actions performed by the RSM for Storage software.

**Security Log**

Opens a console window and displays the most recent entries in the RSM for Storage Security Log. This log contains time stamped entries for actions performed by the RSM for Storage software that affect the security of the system.

---

### Notification e-mails

The RSM for Storage software sends e-mails to notify you about important changes in status.

Remote Access notifications are sent when:

- Remote access is enabled or disabled.

- A remote user connects or disconnects from the system.
- The remote access automatic timeout is about to expire and the system has one or more active alerts. Timeout warnings are sent at 4 hours, 2 hours and 1 hour before the timeout occurs.

Alert Status notifications are sent when an alert has been sent to IBM Service.

Daily Status e-mails serve as a heartbeat notification that the RSM for Storage system is operational. It includes the summary status for the system and status for alerts that may be active for storage subsystems.

Firewall Status notifications are sent when the internal firewall for the RSM for Storage system is enabled or disabled.

Ping Checks of the configured SMTP sever and Management Station are performed each half hour. Ping Check notifications are sent when two ping checks in a row fail.

Ignored Event notifications are sent when an event is received that is configured to be ignored by the RSM for Storage system. These are events for which a response by IBM Service is not usually required. See Appendix F, "Filtered events," on page 83 for a description of these events.

Phone Line Check notification is sent if the RSM for Storage system can not verify that an active phone line is connected to the modem. The check is run daily after midnight local time.

---

## E-mail contacts

When the RSM for Storage software was configured, you selected one of the contact persons to be the Primary Contact for the RSM for Storage system. Additional contacts might have been associated with different storage subsystems.

Table 4. E-mail contacts

Notification	Primary contact	Subsystem contact
Remote Access is enabled or disabled.	X	
Remote User connects and logs into the RSM for Storage system or logs out.	X	
Firewall is enabled or disabled.	X	
Remote Access is about to expire or has expired.	X	X
An alert occurs for a subsystem.	X	X
Daily status updates at local noon.	X	
Daily status updates at local noon when a subsystem has an active alert.	X	X
Daily phone line check fails.	X	
Ping Check fails.	X	
RSM receives an event it is configured to ignore.	X	X
Notifications from IBM Support or RSM for Storage Development about the availability of updates to RSM for Storage software.	X	

---

## Browser interface

Management of the RSM for Storage system is performed with a Web browser.

The management page can be accessed on the RSM for Storage system with the URL: localhost, or by clicking the Manage icon on the desktop.

Remote management can be performed using HTTPS by specifying the hostname of the RSM for Storage system or its IP address. (for example: https://192.168.1.100).

During installation of the RSM for Storage software, self-signed SSL certifications are created for use with the HTTPS interface. Any warnings you receive from your browser can be ignored.

---

## Management pages

There are four management areas:

- System configuration
- Firewall
- Remote access
- Reporting and alerts

## System configuration

The system configuration page allows you to specify the following:

- Company name and address.
- One or more contact people that IBM Service should call or e-mail when responding to a problem report.
- Connection information about the RSM for Storage system.
- Storage subsystems to be monitored by the RSM for Storage system.
- Other SAN devices.
- System activation.

There are three validation checks made on configuration information.

The first check occurs when you click the Update Configuration button on each configuration page. This verifies the format and content of each configuration field. Any problems will be indicated with a Configuration Incomplete status.

When all configuration Incomplete problems have been fixed, an option will be available at the bottom on the System Configuration page to run a Configuration Test. This test checks that the RSM for Storage system has IP connectivity to all configured SAN devices, that the system can communicate with the attached external modem if configured, and that each of the storage subsystems can be contacted. Any problems detected during the test are will be indicated with a Configuration Problem status.

**Note:** The RSM for Storage software will not process any events until all configuration errors are corrected and the System Activation step has been completed.

A third configuration check occurs each day when each storage subsystem is contacted to verify connectivity. This check will detect the following:

- If a new version of controller firmware has been installed. This will require an update to RSM for Storage for compatibility.
- If any new drive expansion enclosures have been added to the subsystem. When a new enclosure is detected, the configuration status for the subsystem in RSM for Storage will change to Incomplete and you will need to add the IBM Machine Type and Serial number for the enclosure to the RSM for Storage configuration.

For more information refer to Chapter 2, “Installation overview,” on page 13 or “Configuration procedures and issues” on page 39.

## Firewall

The firewall page provides status for the RSM for Storage server internal firewall. The purpose of the internal firewall is to limit the scope of access that local and remote users of the system have to your network.

The normal state for the firewall is Enabled:Closed which means that the firewall is operational and configured to allow SNMP traps to be received and e-mails to be sent, however, access to other devices on your network is not allowed.

The Enabled:Custom state indicates that one or more custom rules have been added to `/etc/rsm/rsmfirewall.conf`. These rules will be active any time the firewall is enabled.

The Enabled:Open state means that access to one or more other devices has been enabled. The firewall allows access to any storage subsystem that has an active alert, and also storage subsystems and other SAN devices that have been placed in Service Access mode.

Service Access mode allows you to manually allow access to a device from the RSM for Storage system. You can select storage subsystems or "Other SAN Devices" that you have previously configured.

Disabling the firewall allows unrestricted access from the RSM for Storage system to your network. To maintain the security of your network, disabling the firewall will also disable remote access. Likewise, enabling Remote Access will automatically enable the firewall.

## Remote access

The Remote Access page provides controls and status for Remote Access to the RSM for Storage system. Enabling Remote Access unlocks the rservice user ID and depending on your configuration, allows the modem to answer an incoming call, or enables the firewall to accept SSH connections.

Once enabled, when a remote user connects to the system, the status will change to Active.

You can select to have Remote Access automatically enabled when an alert is sent to IBM Service. Or you can wait to be contacted by IBM Service by phone before manually enabling it.

This page also allows you to set the Remote Access Timeout. This guarantees that the system will return to a secure state, without intervention. If the problem is difficult to resolve, or occurs intermittently, you may need to refresh the timeout to allow IBM Service more time to work on the problem.

If you disable Remote Access while a remote user is connected, the remote user will be disconnected.

## Reporting and alerts

Normally all configured storage subsystems will be enabled for reporting. This means that RSM for Storage will accept and process any events related to the subsystem. If you are relocating a subsystem or performing any task that might generate events (that IBM does not need to respond to), you can disable reporting until the subsystem is fully operational again.

While you are making configuration changes to the RSM for Storage software, the Reporting Status may be "Suspended". This is a reminder that no events will be processed by the RSM for Storage system while any configuration problems exist.

This page shows a summary of all alerts being tracked by the RSM for Storage software and allows you to view details about alerts that are active for each subsystem.

When a subsystem first reports a problem, an alert is sent to IBM Service. Once IBM has been alerted to the problem, additional alerts for that subsystem are usually held at the RSM for Storage system. However, if another event for the same subsystem occurs and indicates a hardware failure that is different from the previously sent alert, the new alert will also be sent to IBM.

IBM will respond to the alert by connecting to the RSM for Storage system at which time they will either acknowledge or close all of the alerts for the subsystem. Alerts are acknowledged to indicate they have been seen by IBM Service but work on the problem has not been completed. Closing all of the alerts for a subsystem indicates that service is complete.

When all alerts for a subsystem are closed, the RSM for Storage software will consider the next event from that subsystem to be a new problem and an alert will be sent to IBM Service.

The Reporting and Alerts page will show the number of alerts sent, acknowledged and pending for each subsystem that has active alerts.

Pending alerts are ones that are candidates to be sent to IBM Service, but are being held at the RSM for Storage system for one of three reasons.

### **Holding**

Another alert has already been sent to IBM Service for the subsystem.

### **Queued**

The RSM for Storage software attempted to send the alert, but received an error. The most likely cause is a network problem that prevents the RSM for Storage software from reaching the SMTP server. The RSM for Storage software will attempt to re-send the alert every few minutes.

### **Waiting**

IBM Service was remotely connected to the RSM for Storage system when the alert occurred. If all other alerts have been closed and the remote user disconnects without acknowledging this alert, it will then be sent to IBM Service as a new problem.

## Navigation links and status summary



Navigation links at the top and bottom of each page allow you to move backwards to any previous level.



At the top of each page two lines of summary status for the four management areas are displayed. You can navigate to any of the management pages by clicking on the names in the summary status lines.

In addition to the text status, icons are used when your attention is required:

Table 5. Status summary icons

	An information status indicates a normal condition that is expected when a change to reporting, firewall, or remote access status occurs.
	A condition that usually requires your attention or awareness.
	This indicates a problem that prevents the RSM for Storage system from reporting subsystem problems to IBM.

## Help pages

Each of the management pages in the browser interface has a link to a help page:

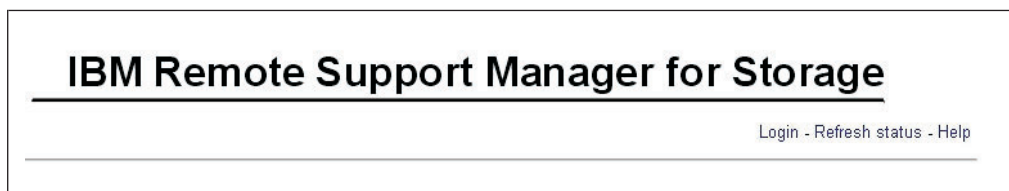

Refer to these help pages for questions about the meaning of status indications, controls, options or format of configuration fields.

In addition, the help page for the Main Menu contains a link to a master help index page that has general help for the following topics.

- Desktop icons
- Systems users and capabilities
- Browser user interface
- Command line utilities
- Configuring IBM DS Storage Manager to work with RSM for Storage
- Saving and restoring configuration files
- Troubleshooting



---

## Configuration procedures and issues

The following sections provide detailed information about the following configuration procedures:

- Adding a new subsystem
- Changing who emails appear to be from
- Changing who receives e-mails
- Changing passwords
- Saving and restoring configuration files

### Adding a new subsystem

To add a new subsystem, do the following:

1. Ensure that the new subsystem is covered under warranty or a current IBM maintenance agreement.
2. Add the subsystem to the RSM for Storage configuration by doing the following:
  - a. Use the exact hostname used in IBM DS Storage Manager.
  - b. Make sure to enter the correct IBM machine type, model and serial number.
  - c. Include the IP addresses of the controllers.
  - d. Include the location of the subsystem.
  - e. Select the contact person that is physically near the subsystem.
3. Run the Configuration Test to verify IP connectivity and hostname.
4. After the configuration test runs, additional fields for configuring the IBM machine type and serial number for any newly discovered drive expansion enclosures will be included on the subsystem configuration page.

### E-mail Transport options

The RSM for Storage software can send e-mail to your SMTP server to be forwarded to the destination, or it can send e-mails directly to the destination.

The default configuration value for the SMTP server IP address is "DIRECT", which will cause the RSM for Storage system to send e-mails directly to the destination. You may also specify the IP address (xxx.xxx.xxx.xxx) of your SMTP e-mail server.

If using DIRECT, one reason that e-mails may not be delivered is because your company's firewall may only forward e-mails sent from your e-mail server. Specifying the IP address of your SMTP e-mail server should resolve this problem.

If using the IP address of your SMTP e-mail server, one reason that e-mail may not be delivered is because the filtering on your e-mail server may be blocking e-mails sent by the RSM for Storage system. Some e-mail filtering programs may forward e-mails sent by the RSM for Storage system but will remove the ZIP file attachment that contains the log files. Check with the administrator of your e-mail server to determine if a special rule for the RSM for Storage system is required.

### Changing who emails appear to be from

You can change the from root field and the domain used to send e-mails.

#### Changing the from root field on e-mails

To change the from root field on e-mails, create the file /etc/Muttrc and insert the following line:

```
set from="name_of_your_choice"
```

## Changing to domain used to send e-mails

To change the domain for SLES systems, do the following:

1. Edit the file: `/etc/postfix/main.cf`
2. Uncomment the `mydomain =` line by removing the pound sign and set it equal to the domain for your site. Such as `mydomain = ibm.com`
3. Then about 15 lines down in the file, uncomment the "`myorigin =`" line, and set it to `myorigin = $mydomain`
4. Restart Postfix by entering: `/etc/init.d/postfix restart`

To change the domain for RHEL systems, do the following:

1. Edit or create the file: `/etc/Muttrc`
2. Insert the following line:  
`my_hdr From: Joe Smith <jsmith@your_domain.com>`

## Changing who receives e-mails

To change who receives e-mails notifications, do the following:

1. Add or verify the person's information in the Contacts page in System Configuration.
2. To change the primary contact person for the RSM, check the box at the bottom of the configuration page for that person.
3. To change the contact for a specific storage subsystem, go to the subsystem's configuration page and choose from the list of configured contact people. The contact for a subsystem should be physically near the subsystem so they can work with IBM Service if required.

**Note:** If e-mail addresses in your company are not exceptionally long, you can have e-mails sent to two addresses. Add a second e-mail address by adding a space after the existing e-mail address; then, type the second e-mail address.

## Changing passwords

Use the command `rsm-passwd` to set the passwords for the RSM for Storage browser user interface:

1. Log in to the server running the Remote Support Manager software as the "root" user.
2. Open a console window and type: `rsm-passwd admin` or `rsm-passwd lservice`.

To change the Linux log in passwords, use the command `passwd`.

## Saving and restoring configuration files

The configuration files are stored in the directory: `/etc/rsm`. These files can be backed up by saving them to a floppy diskette or by using FTP to store them on another machine.

**Note:** When you update the RSM for Storage software, the configuration files are preserved. However if you should ever need to install the RSM for Storage software on a new server, having a backup copy will save considerable time.

### Saving the configuration files

Log in to the server running the Remote Support Manager software as the "root" user. Open a console window and type: `rsm-cfg-save`. The program will create a compressed file containing the configuration files. This file is stored as:

/packages/rsm-configuration-files.zip. You can then choose to save the file to diskette, or exit the program and manually FTP the file to another machine.

**How to FTP the configuration file to another machine:** Use the Remote Support Manager's user interface to disable the internal firewall. Note that while the firewall is disabled, the RSM for Storage software will continue to process events, but will not automatically enable Remote Access.

**Attention:** Be sure and remember to re-enable the firewall.

As the root user, open a console window and:

1. Run the `rsm-cfg-save` program as described in the previous section.
2. Use FTP to copy the file `/packages/rsm-configuration-files.zip` to another machine.
3. Close the console window.

Use the Remote Support Manager's user interface to re-enable the internal firewall.

### **Restoring saved configuration files**

Place the saved configuration file (`rsm-configuration-files.zip`) in the `/packages` directory. As the root user, open a console window and do the following:

1. Run the `rsm-cfg-restore` program.
2. Run `rsm-stop`.
3. Run `rsm-start`.
4. Close the console window.

---

## **Power off/on sequence**

If you are powering your SAN off for maintenance, the RSM for Storage system should be powered off first and back on last, in order to prevent reporting of events that may be associated with power cycling of other devices.

---

## **Working with IBM Service**

This section provides details about using RSM for Storage to work with IBM Service to resolve issues.

### **Enabling remote access**

On the Remote Access management page, you have the option of allowing remote access to be automatically enabled when an alert is sent to IBM. This allows IBM to connect to the RSM for Storage system without needing to first speak with the contact person for the system. If you choose to disable this function, IBM Service will contact you to have remote access enabled manually when an alert is received.

### **Acknowledging alerts**

The acknowledge state of an alert is an indication that IBM Service has seen or is aware of the alert. When IBM Service dials into the RSM for Storage system they will view the existing alerts and acknowledge them. In some situations, IBM Service may not require remote access to the RSM or subsystem in order to determine the cause of a problem and may call you to discuss the problem resolution. You can also acknowledge (or close) alerts.

## Closing alerts

The RSM for Storage software sends an alert to IBM Service for the first event reported for a subsystem and for each unique event that indicates a hardware failure.

Additional alerts that occur (usually related to the initial event) are held by the RSM for Storage system and are available for examination by IBM Remote Support when they connect to the RSM for Storage system in response to the initial alert. When all active alerts for a subsystem are closed, the next event for that subsystem will again be sent to IBM Service.

Closing an alert in the RSM for Storage software, does not close the problem report with IBM Service.

## Remote access timeout

To ensure that you do not have to remember to disable remote access to the RSM for Storage system in order to make it secure, the RSM for Storage software will automatically disable Remote Access based on a timeout. You can configure this timeout for between 12 and 96 hours. Some intermittent problems may require occasional access by IBM Service over a period of days and it may be necessary for you to extend the timeout. To extend the Remote Access Timeout, click the "Update Remote Access Timeout" button on the Remote Access management page.

## Providing additional privileges

When the RSM for Storage sends an alert to IBM, it often will contain all the information needed to identify the problem. When IBM Service dials into the RSM for Storage system, they will be able to connect to those subsystems that have reported a problem. Depending on how you have specified options in IBM DS Storage Manager, IBM's access may be limited to viewing configuration and downloading logs. If additional access is required to resolve a problem, you may need to:

- Provide IBM with the password for the subsystem.
- Enable RLOGIN or TELNET for the subsystem so the controller's shell interface can be accessed.

## Performance issues or other concerns that do not trigger an alert

When you place a voice call to IBM for Service, you can provide IBM Service with access to the RSM for Storage system and to storage subsystems, switches or hosts in your network. You can manually enable Remote Access to the RSM for Storage system and place any configured storage subsystem or other SAN device in Service Access mode and provide IBM Service with the phone number of the modem connected to the RSM for Storage system.

Note that the RSM for Storage system is normally used by the IBM Support Centers supporting storage subsystems. Support Centers for other devices such as switches will not be familiar with uses of the RSM for Storage system and may not have immediate access to the internal IBM tools that enable log in to the RSM for Storage system.

---

## Event filtering and handling

The RSM for Storage software does not directly monitor storage for problems. Your existing IBM DS Storage Manager software already polls each subsystem looking for problems. DS Storage Manager is configured to send critical events to the RSM for Storage systems as SNMP traps.

### Ignored Events

Any SNMP trap that does not come from a DS3000, DS4000, or DS5000 subsystem via DS Storage Manager is ignored.

Events that are received for a storage subsystem that is not configured or has had reporting disabled are ignored.

A few critical events reported by DS Storage Manager do not usually require a response by IBM Service. These are normally reported to the configured contact person for the subsystem via e-mail. See Appendix F, “Filtered events,” on page 83 for a list of events that are ignored by the RSM for Storage software.

### Duplicates

Some failures result in duplicate event codes being sent to the RSM for Storage system. When duplicate events are detected, a duplicate count is incremented for the previous Alert.

---

## Security

Adding a modem or enabling SSH connections to one of your systems creates a potential entry point for unauthorized access to your network. RSM for Storage software modifies many characteristics and behaviors of the system it is installed on to protect this entry point and to maximize the amount of control you have in managing remote access. To ensure the integrity of these controls, you should consider the server the RSM for Storage software is installed on to be a single purpose appliance.

RSM for Storage controls initial access to the system by remote users and then manages an internal firewall to limit the scope of access a remote user has to your network.

### Access to the RSM for Storage system

Remote Access to the RSM for Storage system (and through it to the storage subsystems), allows IBM Service to resolve problems with no or minimum participation by your staff. We realize that the security requirements of some environments will not permit remote access regardless of what controls are in place. RSM for Storage can be configured to 'one-way call home', but doing so will require greater involvement by your staff in order to resolve some problems.

To know more about One-way Call Home and how to enable it, refer to “Enabling One-way Call Home” on page 47.

Remote access to your system has the following four layers of control:

- The modem is configured to only answer when Remote Access is enabled by the RSM for Storage software. Likewise, the SSH port for remote access is only allowed to respond to connection attempts when Remote Access is enabled.

You can manually enable and disable remote access, or you can choose to have remote access automatically enabled when a storage subsystem reports a problem. When remote access is enabled a timer is started which will automatically disable remote access when it expires. You don't have to remember to make the system secure after service has been completed.

The person identified as the primary contact for the RSM for Storage system is notified by e-mail whenever a change in the remote access settings occurs and all state changes are also written to the Security Log.

- The userid reserved for remote access (rservice) is only valid when Remote Access is enabled. Attempts to log in using the root, admin or lservice userids using the modem or remote SSH connections are rejected.

**Note:** For this reason you should not create additional users on this system.

- The initial login password is changed daily at midnight UTC. IBM Service has an internal tool that provides the current password for RSM for Storage systems.
- After validation of the initial login password, remote users are presented with a challenge string, which also requires access to an internal IBM tool in order to obtain the correct response. The response also includes an IBM employee user name that is recorded in the RSM for Storage Security Log.

## Scope of access to your network

The following sections provide detailed information about the different user access permissions and privileges available in your network.

### User permissions and privileges

Once a remote user has logged into the RSM for Storage system, that user will have all of the privileges of a normal user that is logged into the system locally. The only users that should exist on the system are those created by RSM for Storage software (such as admin, lservice and rservice).

- **root** has complete control of the system and should be used only for installation of software or maintenance.
- **admin** performs configuration and management of the RSM for Storage software. The password for this user is set by the root user of the system.
- **lservice** is primarily intended for use by on-site IBM Service. This user can acknowledge and close alerts and view configuration settings. The lservice user can log into the system locally and is also recognized by the RSM for Storage browser interface. The password for this user is set by the root user of the system.
- **rservice** is used by IBM Service and is only valid on the remote modem or SSH connection.

The Switch User (su) command is disabled to prevent a normal user from attempting to become "root" and have unrestricted access to the system. The RSM for Storage software makes other changes in program and directory permissions to limit what programs and files these users can access.

### Password complexity for the browsers interface

The root user can, specify 4 options for password complexity by editing and adding keywords to the `/etc/rsm/rsm-options.conf` file.

These checks are made when setting the passwords for the RSM browser using the command `rsm-passwd`. They are independent of the Linux account passwords.

the following keywords can be placed anywhere in the file.

- PASSWORD\_REQUIRE\_LENGTH nn (where nn is minimum length from 6 to 15)
- PASSWORD\_REQUIRE\_UPPER
- PASSWORD\_REQUIRE\_LOWER
- PASSWORD\_REQUIRE\_NUMBERS

After saving the file, restart RSM for Storage with the command *rsm-start*.

## IP connections

The remote connection made by IBM into the RSM for Storage system is a console interface and programs that can initiate an IP connection on this interface are removed from the system during installation of the RSM for Storage software.

The following programs are removed from the system during installation of the RSM for Storage software:

- rcp
- rsh
- rexec
- tftpd
- vsftpd
- telnetd

**Note:** rlogin, which is required for shell access to DS3000, DS4000, and DS5000 storage subsystems, is not removed.

The only IP related daemons (or services) running on the RSM for Storage system are snmptrapd, sshd and httpd, which listen for SNMP traps, secure shell session requests and HTTP(S) requests respectively.

## Firewall states

The RSM for Storage software manages an internal firewall that limits the IP destinations that can be accessed by local and remote users of the system. The "rules" for inbound and outbound IP traffic that control the internal firewall are managed dynamically by the RSM for Storage software. There are three general states the firewall can be in:

### Disabled:

All IP traffic is permitted both into and out of the system.

### Enabled: Closed:

This is the normal state when there are no active alerts present and the system is waiting for notification from IBM DS Storage Manager of a problem.

- The firewall will accept incoming SNMP traps, ping, traceroute and HTTPS requests.
- Outbound traffic for DNS, ping, traceroute, IBM's WWW and FTP sites and port 25 of your configured SMTP (e-mail) server.
- There is no access to any of your configured SAN devices or other addresses except as previously noted.
- Forwarding of IP traffic is also disabled, which prevents the system from being used as a router.

### Enabled: Open:

In this state, outbound access to one or more configured storage systems or other configured SAN devices is also permitted. Access is allowed only

to those devices that have active alerts or those that you have placed in Service Access mode. If you have defined any custom firewall rules, those rules will also be in effect.

**Enabled: Custom:**

This state will be seen in place of Enabled: Closed when one or more custom firewall rules has been configured in `/etc/rsm/rsm-firewall.conf`. Custom rules may allow SSH access on your local network for administration. When RSM for Storage is included as part of an IBM Solution, rules may be created to allow communication with other elements in the solution.

**Side effects of the firewall operation**

The internal firewall is managed to allow access to specific devices in your network only at the time they require service. For this reason, the RSM for Storage system will not be suitable for running management applications such as IBM DS Storage Manager or IBM Director.

## Customizing the firewall

If you determine that it is appropriate for all local and remote users of the RSM for Storage system to be able to access other systems in your network at any time, you can create a configuration file that will enable access to them through the internal firewall. This configuration file can only be created or modified by the root user. See Appendix G, "Customizing the firewall," on page 85.

**Note:** Creating custom rules in order to allow other applications (not tested with RSM for Storage) to run on the RSM for Storage server is not recommended. Future updates to RSM software may cause these applications to stop working or impact operation of the RSM for Storage software.

The Linux system management tool (YaST) tool may show that the Linux firewall is disabled or "managed by another program". This is expected as the RSM for Storage software is managing the firewall.

### Managing the system using SSH

If you wish to manage the RSM for Storage server from inside your network using SSH with a root login, make the following configuration changes. Note that on the Connections configuration page there is a place to specify the SSH port that the RSM for Storage system uses to listen for remote connections. To establish local SSH connections you must choose a different port number. The port number to be used for local SSH connections is specified by editing the file: `/etc/rsm/rsm-firewall.conf`. To create this file, rename `/etc/rsm/rsm-firewall.conf.sample` to `/etc/rsm/rsm-firewall.conf`.

Uncomment the following lines:

```
SSHD_ALLOWED nn
SSHD_ROOT_ALLOWED
```

Specify the port number to be used for local SSH access following the keyword `SSHD_ALLOWED`. Then run `rsm-start` for the configuration changes to be read and the SSH daemon for local access initialized. Review the last entries in the file RSM Security Log file to verify that the SSH setup completed.

By having two different SSH daemons for remote and local connections, RSM for Storage can ensure that no one can attempt to access the system remotely using



the root user ID. Attempts to log into this SSH port as the admin, lservice or rservice user will cause the session to be dropped.

## Log in to SAN devices

While the RSM for Storage internal firewall can limit the scope of access to your network, you must ensure that passwords and services running on your SAN devices are secure. DS3000, DS4000, and DS5000 controllers have two levels of user login: Operator and Administrator.

The RSM for Storage system includes the DS Storage Manager CLI program (SMcli) which is used to access storage controllers. The default permissions for SMcli are that of an operator that can view settings and download logs, but cannot change the configuration or load new software. Access to the administrator commands require use of a password. It is recommended that you install this password and provide it to IBM Service when required to resolve a problem.

A lower level of access to the controller is the shell interface. The controller shell can be accessed from the RSM for Storage system with RLOGIN without a password (if the RLOGIN service is enabled for the controller). IBM DS Storage Manager has an option to disable RLOGIN and it is recommended that RLOGIN normally be disabled. IBM Service will contact you if shell access is required to resolve a problem.

The RSM for Storage software enables you to place other configured SAN devices in Service Access mode thereby allowing IP connections to them from the RSM for Storage system. You should ensure that proper user IDs and passwords are in place for these systems and provide them to IBM Service as required.

## Information sent to IBM

Information about the storage subsystems configured in RSM for Storage is sent to IBM for problem resolution and operational status evaluation from the storage subsystems. This can include:

- Information entered into RSM for Storage's configuration screens.
- Logs files (support data) for each storage subsystem.
- Hardware and software configuration of each storage subsystem.
- Performance and status information for RSM for Storage.

RSM for Storage does not have access to any of your information stored in the storage subsystem.

## Enabling One-way Call Home

You can use One-way Call Home to configure RSM for Storage and report system problems to IBM Service without Remote Access enabled.

RSM for Storage does not report all critical events that might be reported by IBM Storage Manager to IBM Service. This is because some failures can result in many 'side-effect' events. A prerequisite for electronic call home by IBM products is that only a single problem report should be sent for a single failure. RSM for Storage stores these side-effect events as holding for review by IBM Remote Support. When Remote Access is activated, Remote Support clears all these events after verifying that no additional problems exist.

When One-way Call Home is enabled, IBM Remote Support will no longer be able to review and clear these additional events. RSM for Storage compensates for this by polling the subsystem and looking for the health status to return to optimal state.

In case of a second failure on the subsystem (before the first failure being fixed), the subsystem will not return to optimal state until the second problem is fixed. RSM for Storage checks if another hardware component is affected and if so, sends the second problem report. However some of the side-effect events are ambiguous and RSM for Storage cannot determine whether a hardware failure triggered an event.

The IBM SSR or customer that replaces a part must verify that a subsystem has returned to optimal state after any repair. If additional problems exist, your staff should connect to the RSM for Storage system and determine what alerts have been sent to IBM and if one of the other events being held on the system indicates a different failure. Closing all alerts related to the first problem will cause RSM to send the next alert to IBM (if it has not already done so). Your staff may need to seek assistance from IBM Support if this situation should occur.

Because the occurrence of a double failure, and also the low probability that the resulting events could be ambiguous with regard to whether they are independent of each other, this scenario is unlikely to occur. But if this situation does occur, IBM Remote Support will work with your staff over the phone to resolve the problems.

To enable One-way Call Home:

1. On your browser, go to **System Configuration > Options**.
2. Select **ECC Only** as the problem reporting method.

**Note:** **ECC Only** establishes a direct connection with IBM and you receive immediate acknowledgement of your problem reports.

3. Enable **One-way Call Home**.

---

## Chapter 7. Troubleshooting

This chapter provides information for troubleshooting and resolving problems while working with RSM for Storage.

- “Hardware problems with the server”
  - “Remote Support Manager interactions with server problem determination” on page 50
  - “General tips for troubleshooting problems with System x servers” on page 50
- “Problems with the external modem” on page 50
  - “Quick physical checks” on page 50
  - “None of the indicators light” on page 51
  - “Configuration test problems” on page 51
  - “Verifying the Serial port is enabled in the BIOS” on page 52
  - “The modem will not answer” on page 52
  - “The Phone Line Check fails” on page 52
- “Problems with operation of the RSM for Storage” on page 52
  - “Configuration problems” on page 53
  - “Other problems” on page 53
    - “Icons for RSM for Storage on the desktop are missing or do not work” on page 53
    - “Events for a subsystem are not reported by RSM for Storage” on page 53
    - “RSM does not indicate a problem that appears in DS Storage Manager” on page 54
    - “Multiple e-mails about the same problem” on page 54
    - “A problem detected by the RSM for Storage software, but no e-mail was sent and the status of the alert is “Queued”” on page 55
    - “E-mail received that said the event was ignored and not sent to IBM Service” on page 55
    - “After an earlier problem was resolved, the RSM stopped sending alerts to IBM” on page 55
    - “I/O error message in IBM DS Storage Manager when trying to validate SNMP trap configuration” on page 55
    - “Log files are not sent to IBM” on page 55
- “Calling for help” on page 55

---

### Hardware problems with the server

This section addresses problems with the server that the Remote Support Manager is running on. If you are having problems with the operation of the Remote Support Manager software see “Problems with operation of the RSM for Storage” on page 52.

If you are experiencing a hardware problem with the server hosting RSM for Storage, contact System x support and provide the IBM machine type and serial number of the server.

## Remote Support Manager interactions with server problem determination

Because the Remote Support Manager software automatically controls an internal firewall, you should stop the Remote Support Manager before trouble shooting a possible hardware problem. You can also uninstall the Remote Support Manger software . Configuration files are not removed during an uninstall, and you can quickly re-install it after resolving the hardware problem without needing to re-configure it or perform the activation.

### To stop the Remote Support Manager

Log in to the server as the "root" user Open a console window and type: rsm-stop. If there are events being processed, this may take while to complete. When the rsm-stop program completes, the system should now function as a normal workstation.

### To re-start the Remote Support Manager

Log in to the server as the "root" user Open a console window and type: rsm-start.

## General tips for troubleshooting problems with System x servers

IBM System x servers have front panel status indicators and often "Light Path Diagnostics" to identify failing components. If you do not have the documentation for your server, check the inside of the cover for an information label.

System x (xSeries<sup>®</sup>) servers also have a system log that can accessed during POST by pressing the F1 key during the boot process.

Refer to the documentation that came with your System x server for more information. To place a service call for the System x server, call IBM Service and provide the IBM Machine Type and Serial number of the server.

IBM System x Service and Support may ask you to download and run a program called "Dynamic System Analysis". This program should operate normally provided that the Remote Support Manager has been stopped.

---

## Problems with the external modem

- "Quick physical checks"
- "None of the indicators light" on page 51
- "Configuration test problems" on page 51
- "Verifying the Serial port is enabled in the BIOS" on page 52
- "The modem will not answer" on page 52
- "The Phone Line Check fails" on page 52

## Quick physical checks

1. Serial cable is connected to the modem and serial port #1 on the RSM for Storage system. If your server has more than one server port, port #1 is typically next to the keyboard connection.

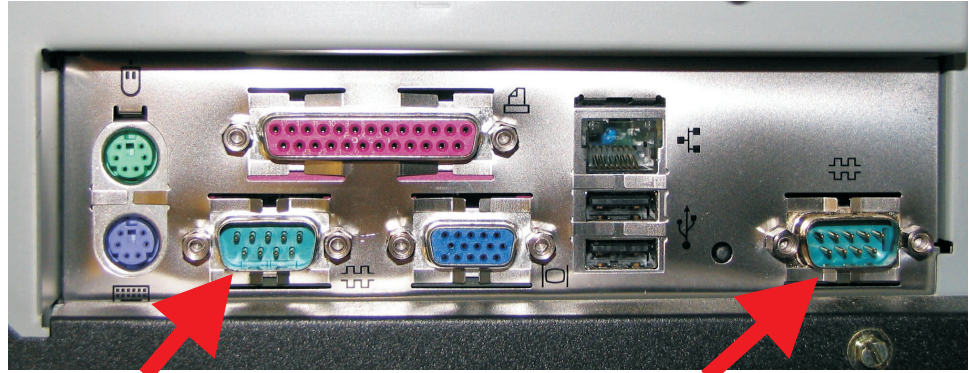

**Serial Port #1 (to modem)**

**Serial Port #2 (not used)**

2. Phone line:
  - Modem is connected to an analog phone line.
  - Phone cable is inserted in the LINE connector on the modem.
3. Modem powers on. See next section.

## None of the indicators light

When you turn on the modem, the LED indicators on the front panel should flash briefly as the modem runs a self-test. If the LEDs remain off, the modem is probably not receiving power. Make sure the modem's power switch is on.

If your modem has a separate power supply, make sure the power supply is firmly connected to the modem and the power supply's power cord is firmly connected to both to the power supply and the wall outlet or power strip.

If your modem is on, try moving the power cord to a different outlet. Test that the outlet is live by plugging another device, such as a lamp, into it.

The modem or power supply may be defective. If you have another, try swapping modems. If the problem goes away, the first modem or power supply might be defective. Call the modem manufacturer's technical support for assistance.

## Configuration test problems

If the modem is not detected when the Configuration Test is run, the modem phone number on the "Connections" configuration page will be flagged with a double asterisk. The Activity Log will also contain an error message related to the modem.

If no problem is indicated, the system is able to communicate with the modem.

### Possible causes of a configuration test error

1. The serial port is disabled in the BIOS (see procedure in the next section).
2. The serial cable is plugged into the wrong serial port (see previous section).
3. Try resetting your modem by turning it off and on.
4. If the modem is on, the cable is plugged into the correct port, the fault might be in the serial cable.
  - Make sure it is firmly connected at both ends.
  - If this the first time you have used the cable, it may be damaged.
  - Check the cable description on the packaging to make sure the cable is the right one for your computer.

- If you are using a serial cable other than the one that came with the modem, make sure it is not a "Null Modem" cable.
5. The serial port might be defective.
  6. The modem might have a problem beyond the scope of the user guide. If another modem is available, try swapping modems. If the problem goes away, have customer call Multi-Tech Technical Support for assistance (see the Multi-Tech documentation for contact information).

## Verifying the Serial port is enabled in the BIOS

Refer to "Updating the server firmware" on page 14.

## The modem will not answer

If the configuration Test passes, but the modem will not answer, make sure that Remote Access is enabled in the RSM for Storage software. This will enable the modem to answer when called.

Verify modem connectivity by calling the modem phone number from a voice phone. If there is no indication that a call is being received:

- Plug the phone cable into a voice phone and verify that a dial tone is present.
- If a dial tone is present, dial the number again and verify that the phone you just connected rings.
- Reconnect the phone cord to the modem connector labeled line #1.

Check the instructions that came with the modem and review any troubleshooting information.

## The Phone Line Check fails

The Phone Line Check attempts to verify that an active phone line is connected to the modem. This check is run during the Configuration Test and daily after midnight local time. If the check fails to verify that an active phone line is present, an e-mail is sent to the primary contact for the RSM system.

There is a configuration field on the RSM browser interface under **System Configuration -> Connections**. This field should be filled in with the shortest phone number required to dial the RSM modem from inside your company's phone system. The Phone Line Check will attempt to dial its own number and expect to receive a BUSY signal if the line is OK.

There may be some combinations of modems, regional phone companies or internal company phone systems where this check can not be performed accurately. If you know the phone line is working and keep getting Phone Line Check failures, the word DISABLE should be entered in the configuration field.

---

## Problems with operation of the RSM for Storage

Configuration problems and various other issues can occur during operation of RSM for Storage. The following sections provide details for troubleshooting these problems.

Also note that each management page in the RSM for Storage browser interface includes a link to a Help page that may help resolve the problem.

If you can't find a resolution to your problem in this document or in the online help, contact IBM Service and provide the IBM machine type and serial number of one of the subsystems connected to the RSM for Storage system.

RSM for Storage interacts with several devices in your network. If you have not already done so, download the latest version of the RSM for Storage Installation Hints and Tips document from [www.ibm.com/storage/disk/rsm](http://www.ibm.com/storage/disk/rsm). The network connection diagram in that document can be very helpful in resolving network related problems.

## Configuration problems

Most configuration problems will be detected when the information is entered or when the **Test Configuration** option is selected. The Configuration Test will verify that all of the configured devices and the SMTP e-mail server can be reached via the Ethernet interface.

Correct any Configuration Incomplete errors and then Run the Configuration Test (on the System Configuration page).

If any problems are indicated, review the RSM for Storage Activity Log. To open the Activity Log, go to the RSM for Storage system desktop and click the Activity Log icon.

You can also open the Activity Log by selecting View Statistics and Logs from the Main Menu.

## Other problems

The following section provides details for troubleshooting and resolving some of the miscellaneous issues that can occur during operation of RSM for Storage.

### **Icons for RSM for Storage on the desktop are missing or do not work**

The most likely cause is that the Gnome desktop was selected instead of KDE during the installation of the Operating System.

1. Log out.
2. On the login screen for the desktop, click **Session**, if KDE is listed as a choice select it and log in as root.
3. If not, as the root user, use YaST to install the software for the KDE desktop.
4. Re-install the RSM for Storage software. (Your configuration files will not be affected).
5. Log in as "lservice", wait about 15 seconds for KDE to initialize the desktop, then open a console by clicking the shell icon.

The desktop icons will be configured for RSM for Storage.

6. Log out, and then log in as "admin". Open a console window and the desktop icons will be configured for RSM for Storage.

### **Events for a subsystem are not reported by RSM for Storage**

The RSM for Storage software relies on your existing IBM DS Storage Manager application to detect problems in your storage subsystem and report them to the RSM for Storage system as SNMP traps. To resolve this problem, do the following:

1. Verify that the IP address of the RSM for Storage system is correctly specified as a destination for SNMP traps in Storage manager. (See 23 in the installation section). Use the **Validate** button on the SNMP configuration window in DS

Storage Manager to send a test trap to the RSM for Storage system. Receipt of the trap can be verified in the RSM for Storage Activity Log.

2. It is possible to configure IBM DS Storage Manager to report events for all subsystem or individual subsystems. It is also possible to reach the Configure Alerts dialogs from either the Task Assistant or from the Edit menu in the Enterprise Window. If alerts were configured starting from the Edit menu in the Enterprise Management window, then alerts may have been configured only for the storage subsystem highlighted in the Enterprise Management window. Use the Task Assistant as described on page 23 in the installation section) to configure alerts for all subsystems.
3. If events are reported sometimes, but not at others, IBM Storage Manger's Event Monitor may not be running on the management station.

The Event Monitor is an installation option for DS Storage Manager that monitors subsystems for problems when the DS Storage Manager client is not running. You must reinstall IBM Storage Manger to activate the Event Monitor.

There is no special configuration for the Event Monitor. Configuring SNMP traps in the DS Storage Manager client also configures the Event Monitor.

### **RSM does not indicate a problem that appears in DS Storage Manager**

DS Storage Manager may not be configured to send SNMP traps to the RSM for Storage system. There are two ways to enter the alert configuration menus in DS Storage Manager:

- If you select Configure Alerts from the Enterprise Management windows and have a subsystem highlighted, your configuration will apply only to that subsystem.
- If you start from the Task Assistant, you will be given the option of configuring alerts for All Storage Subsystems or an Individual Storage Subsystem.

Reporting for the subsystem may have been disabled in the RSM for Storage system.

The event may be one that the RSM for Storage system ignores because it is a problem that usually does not require a response by IBM Service.

### **Multiple e-mails about the same problem**

DS Storage Manager can be configured to send e-mail notifications when a problem is detected. When RSM for Storage is installed, e-mail alerts in DS Storage Manager should be disabled.

To disable e-mail alerts in DS Storage Manager, do the following:

1. Select **Configure Alerts in DS Storage Manager's Task Assistant** and select **All Storage Subsystems**.
2. On the E-mail Tab, delete any configured e-mail destinations.

E-mail notifications from the RSM for Storage have a subject of "RSM for Storage..."

E-mail notifications from DS Storage Manager usually have a subject of "Critical Alert for..."



### **A problem detected by the RSM for Storage software, but no e-mail was sent and the status of the alert is "Queued"**

The RSM for Storage system could not ping the SMTP server when it tried to send an alert to IBM Service. The alert to IBM is retried every five minutes. Customer notifications are not retired.

### **E-mail received that said the event was ignored and not sent to IBM Service**

Some events that do not normally require a response by IBM Service are ignored by the RSM for Storage system. The customer is notified when this situation occurs. See Appendix F, "Filtered events," on page 83 for more information.

### **After an earlier problem was resolved, the RSM stopped sending alerts to IBM**

The RSM for Storage system only sends a single alert to IBM for each problem. Reporting will not resume until all active alerts for a subsystem are closed.

**Note:** The daily status e-mail will include this information.

### **I/O error message in IBM DS Storage Manager when trying to validate SNMP trap configuration**

If you have an internal firewall installed on the management station running DS Storage Manager, make sure it allows access to the RSM for Storage system.

### **Log files are not sent to IBM**

Log files sent to IBM with each alert are in ZIP format. Some e-mail servers may have filters that block attachment of the ZIP file to the outbound e-mail. Check your e-mail server configuration to see if this can be changed to allow ZIP files from the RSM for Storage system.

An alternative solution is to have the RSM for Storage system send e-mails directly. See "E-mail Transport options" on page 39.

---

## **Calling for help**

If you can not find a resolution to the storage system problem in this document or in the online help, contact IBM Service and provide the IBM machine type and serial number of one of the storage systems.

If you have the DS-RSM server, provide the call center with the machine type and serial number of the DS-RSM and the subsystems connected to the RSM for Storage system. If RSM for Storage is installed on your own hardware, provide the call center with the IBM Machine Type and serial number of one of the storage subsystems monitored by RSM for Storage. When you contact the DASD team, tell them your problem is with operation of RSM for Storage.

---

## **Sending log files for RSM for Storage to IBM.**

Log and trace files for the RSM for Storage system are usually needed in order to resolve problems with the operations of the RSM for Storage server or software. Sending these files should only be done when requested to do so. Just sending them if there is not an active service call for the system will not in itself generate a response. These log files can be sent by two methods:

1. Use the command line program rsm-edump.

To send the log file to additional email address, add the email address to the comand: `rsm-edump someone@some_place`.

2. Use the browser menus.

From the main browser page select: **View Statistics and Logs**. I the middle of the Statistics and Logs page is a button "**Send log file**" and an optional field for including an email address.

---

## Appendix A. Installing the SLES 11 operating system

Some System x servers have been tested with RSM for Storage and specific instructions for configuring the BIOS and starting the Linux installation for those servers can be found in the *RSM for Storage - Installation Hints and Tips* document at <http://www.ibm.com/servers/storage/disk/rsm>.

**Note:** Please refer to the *RSM for Storage - Hints and Tips* document for recent updates or corrections to this manual.

---

### Part 1 – SLES 11 installation

Start the installation procedures in the *RSM for Storage - Installation Hints and Tips* document.

The *RSM for Storage - Installation Hints and Tips* document will refer you back to this document. Continue with either Part 2 or Part 3 of these instructions.

Depending on your hardware, there may be additional configuration screens presented that are not referenced here. Contact your IT support staff for assistance.

---

### Part 2- SLES 11 installation

1. Power on the computer and as the system performs the POST and initialization, insert CD #1 for SLES 11 in the CD-ROM drive. The system should boot from the CD-ROM.
2. Click **Installation** from the first screen.
3. Select your language.
4. Run the media check and click **Next**.
5. During the System Analysis, there may be pop-ups to install drivers for detected devices, answer **Yes** or **OK**.

---

### Part 3- SLES 11 installation

1. On the Installation Settings screen, select **New Installation** and click **Next**.
2. On the Clock and Time Zone screen, do the following:
  - a. Set the Region and Time Zone.
  - b. Set the Hardware Clock Set To: UTC.
  - c. Change the Time and Date.
  - d. Click **Next**.
3. On the Server Base Scenario screen, select **Physical Machine** and click **Next**.
4. On the Installation Settings screen, do the following:
  - a. Click **Partitioning** and do the following:
    - 1) Select the hard disk you want to use. Usually it is listed at the top.
    - 2) Click **Next**.
  - b. Click **Software**, the Software Selection and System Tasks window opens.
  - c. Click the **Details** button at the bottom of the list.
    - 1) With the Filter: (upper left of screen) set to **Patterns**, check or uncheck the following applications as indicated. Some selections may already be

checked.

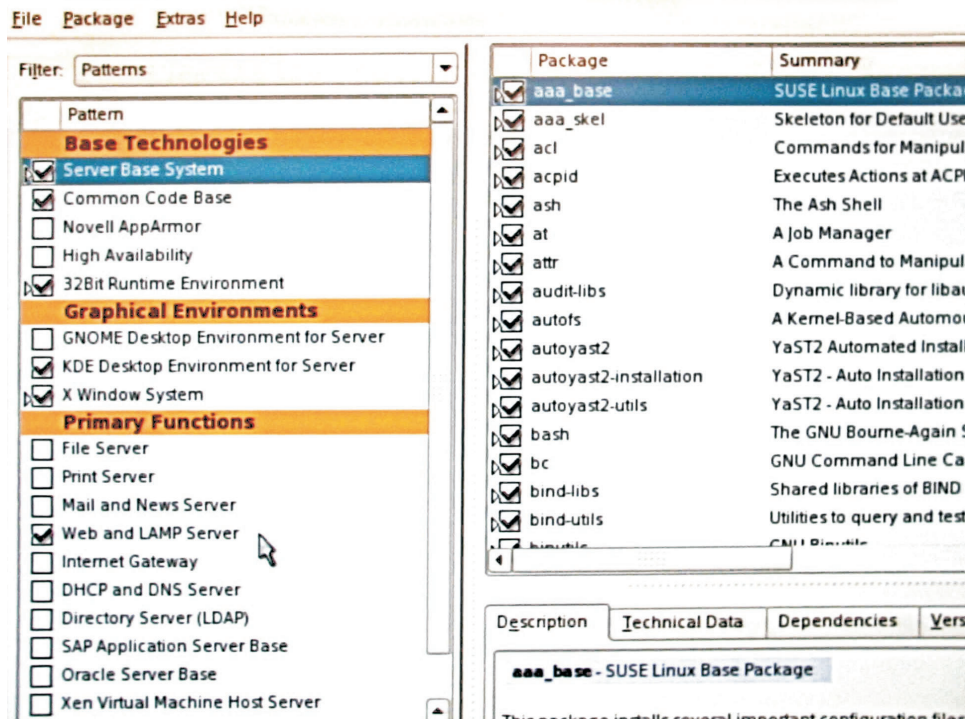

Figure 5. Patterns selection window

- a) Check **Server Base System** (should already be checked).
  - b) Uncheck **Novell AppArmor**.
  - c) Uncheck **GNOME Desktop for Server**.
  - d) Check **KDE Desktop Environment for Server** (required).
  - e) Check **X Window System**.
  - f) Uncheck **Print Server**.
  - g) Check **Web and LAMP Server**.
  - h) Check **C/C++ Compiler and Tools**.
- 2) With the Filter: set to **Search**, do the following:
- a) Type `mgetty` in the search window and click **Search**.
  - b) In the right window, check the box to the left of the `mgetty` package.
  - c) Repeat steps 2a and 2b for `expect`.
  - d) Repeat steps 2a and 2b for `net-snmp`.
  - e) Repeat steps 2a and 2b for `minicom`.

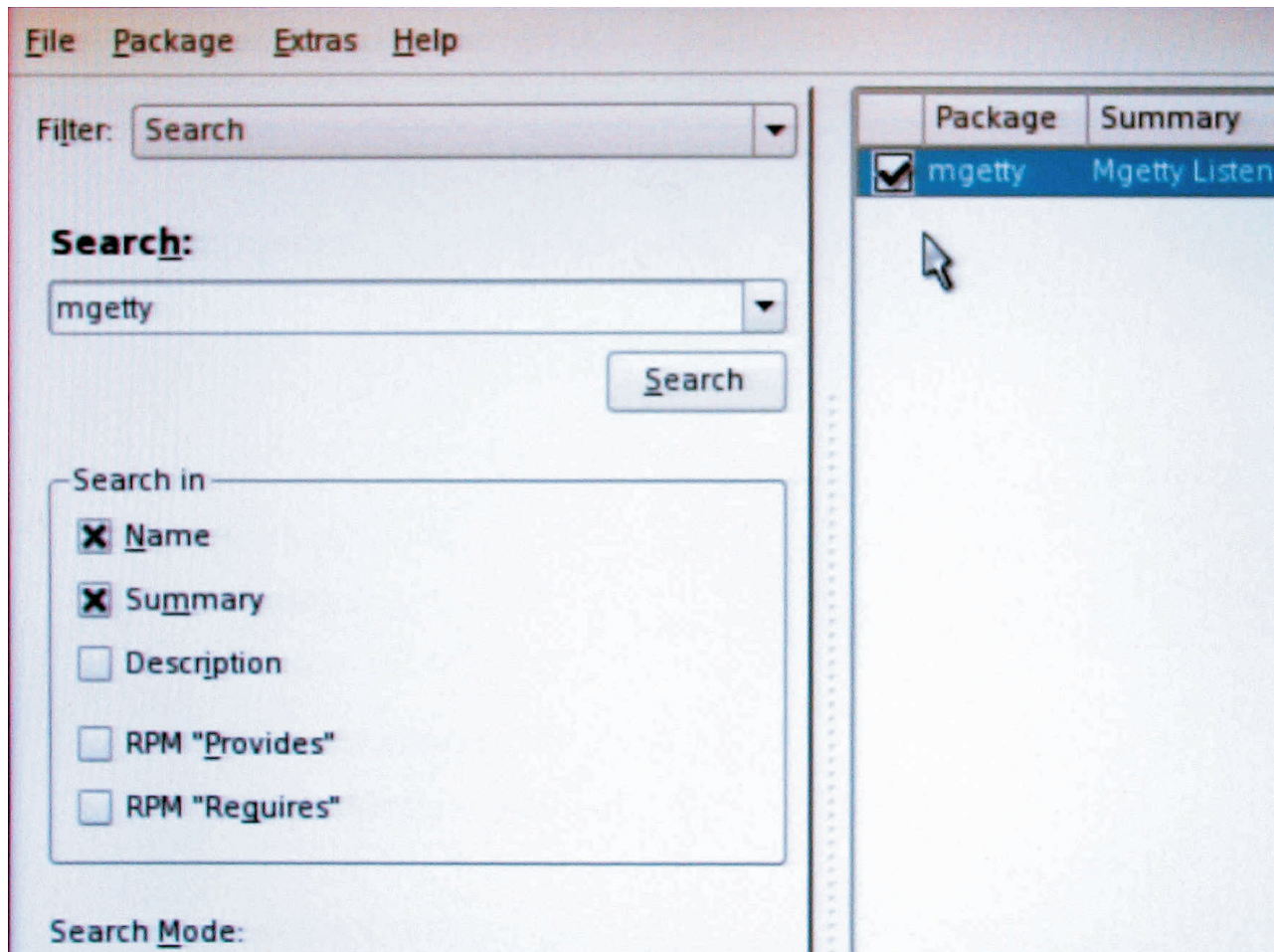

Figure 6. Filter: Search selection window

- 3) Click **Accept** in the lower right of the screen.
- d. Click **Continue** if any Automatic Changes are suggested.
- e. Click **Accept** in the lower right of the screen.
- f. Click **Install** on the Confirm Installation screen. (It may take a long time to prepare the hard disk.)

Insert additional CDs when prompted.

**Note:** During the installation, the system automatically re-boots and presents the initial menu, allow the system to default to the Boot from Hard Disk selection.

5. Provide a password for the root user and click **Next**.
6. On the Hostname and Domain Name screen, do the following:
  - a. Type `ibmrsm` for the Host Name. (If you have another Remote Support Manager installed in your intranet, add a number to the name.)
  - b. Enter your Domain Name.
  - c. Check Write Hostname to `/etc/hosts`.
  - d. Uncheck Change Hostname via DHCP.
  - e. Click **Next**.
7. If the option is present, disable IPv6.
8. On the Network Configuration screen, click **Network Interfaces**.

If you are not sure how to enter network configuration information, check with your network administrator.

The server running the Remote Support Manager must be able to reach the storage subsystems to be monitored, your e-mail (SMTP) server and the Internet. Depending on your network topology this may require one or two network interfaces for this system.

The first Ethernet port is automatically configured for DHCP. You should assign a static IP address for this system.

Click on the name to highlight it and then click **Edit**.

- a. Define a static IP address for this system by doing the following:
  - 1) Click **Static Address Setup** and do the following:
    - a) Enter the static IP address and Subnet Mask for the system.
    - b) Click **Next**.
  - 2) Click **Hostname/DNS** and do the following:
    - a) Verify that the previously entered hostname and domain name are correct.
    - b) Enter the IP addresses of the name servers in your intranet.
  - 3) Click **Routing** and do the following:
    - a) Enter the IP address of the Default Gateway.
    - b) Click **OK**.
- b. If your storage subsystems are on a private LAN, you will need to configure a second Ethernet port to be able to access an SMTP e-mail server and the Internet. Additional unconfigured network adapters/ports will appear in the box at the top of the screen. Click the port to configure and then **Edit** to configure additional ports.

When you have finished configuring all Ethernet ports, click **Next** to exit Network Configuration.

**Note:** It is not necessary to configure the firewall or modem as these will be managed by the RSM for Storage software.

9. On the Test Internet Connection screen, do the following:
  - a. Click **Yes** and **Next**.
  - b. If the test fails, check with your network configuration and verify that the previously entered configuration is correct. You can click **Back** to return to the Network Configuration menus.
  - c. If the test continues to fail contact your IT support staff. You can resolve the network problem after the installation of the OS has completed. Continue the installation by clicking **No, Skip This Test** and **Next**.
  - d. If the test is successful, you will be given the option to configure the system for online updates from Novell.

These may include security updates and should be installed. Load only the recommended security patches.

**Attention:** If you were required to install any device drivers at the start of the installation, *do not* install any kernel updates.

Click **Next** to exit the Novell Customer Center Configuration screen.
10. On the Installation Overview screen, click **Next**.
11. On the User Authentication Method screen, select **Local** and click **Next**.
12. On the Add a New Local User screen, click **Next** and **Yes** to the pop-up window. (RSM for Storage will create users when it is installed.)

13. Review the Release Notes and then click **Next**.
14. On the Hardware Configuration screen, you should change the monitor and screen resolution to 1024x768 or 1280x1024 if supported by your monitor. To change the settings click each of the following settings to the right of Monitor under the Graphics Cards section:
  - a. Monitor Type
  - b. Aspect Ratio
  - c. Resolution
15. Click **Next** to exit the Hardware Configuration window.
16. On the Installation Completed screen do the following:
  - a. Uncheck **Clone this system for AutoYaST**.
  - b. Click **Finish**.
17. On the Login screen, do the following:
  - a. Click Session Type (in the lower left corner of the screen), select **KDE**.
  - b. Log in as user `root` using the previously entered password.
  - c. If you are asked whether you want to make KDE the default for future sessions, click **Make Default**.
18. For any additional steps, refer to the *RSM for Storage - Installation Hints and Tips* document at <http://www.ibm.com/servers/storage/disk/rsm>. Then, Continue with Chapter 3, "Installing RSM for Storage," on page 17.





---

## Appendix B. Installing the SLES 10 operating system

Some System x servers have been tested with RSM for Storage and specific instructions for configuring the BIOS and starting the Linux installation for those servers can be found in the *RSM for Storage - Installation Hints and Tips* document at <http://www.ibm.com/servers/storage/disk/rsm>.

**Note:** Please refer to the *RSM for Storage - Hints and Tips* document for recent updates or corrections to this manual.

---

### Part 1 – SLES 10 installation

Start the installation procedures in the *RSM for Storage - Installation Hints and Tips* document.

The *RSM for Storage - Installation Hints and Tips* document will refer you back to this document. Continue with either Part 2 or Part 3 of these instructions.

Depending on your hardware, there may be additional configuration screens presented that are not referenced here. Contact your IT support staff for assistance.

---

### Part 2- SLES 10 installation

1. Power on the computer and as the system performs the POST and initialization, insert CD #1 for SLES 10 in the CD-ROM drive. The system should boot from the CD-ROM.
2. Click **Installation** from the first screen.
3. Select your language.
4. Respond to the license agreement.
5. During the System Analysis, there may be pop-ups to install drivers for detected devices, answer **Yes** or **OK**.

---

### Part 3- SLES 10 installation

1. On the Installation Settings screen, select **New Installation** and click **Next**.
2. On the Clock and Time Zone screen, do the following:
  - a. Set the Region and Time Zone.
  - b. Set the Hardware Clock Set To: UTC.
  - c. Change the Time and Date.
  - d. Click **Next**.
3. On the Installation Settings screen, do the following:
  - a. Click **Partitioning** and do the following:
    - 1) Select **Create Custom Partition Setup** and click **Next**.
    - 2) For Hard Disk: select **1** and click **Next**.
    - 3) If **Use entire disk** is an option, select it.
    - 4) Click **Next**.
  - b. Click **Software**, the Software Selection and System Tasks window opens.
  - c. Click the **Details** button at the bottom of the list.
    - 1) With the Filter: (upper left of screen) set to **Patterns**, check or uncheck the following applications as indicated. Some selections may already be

checked.

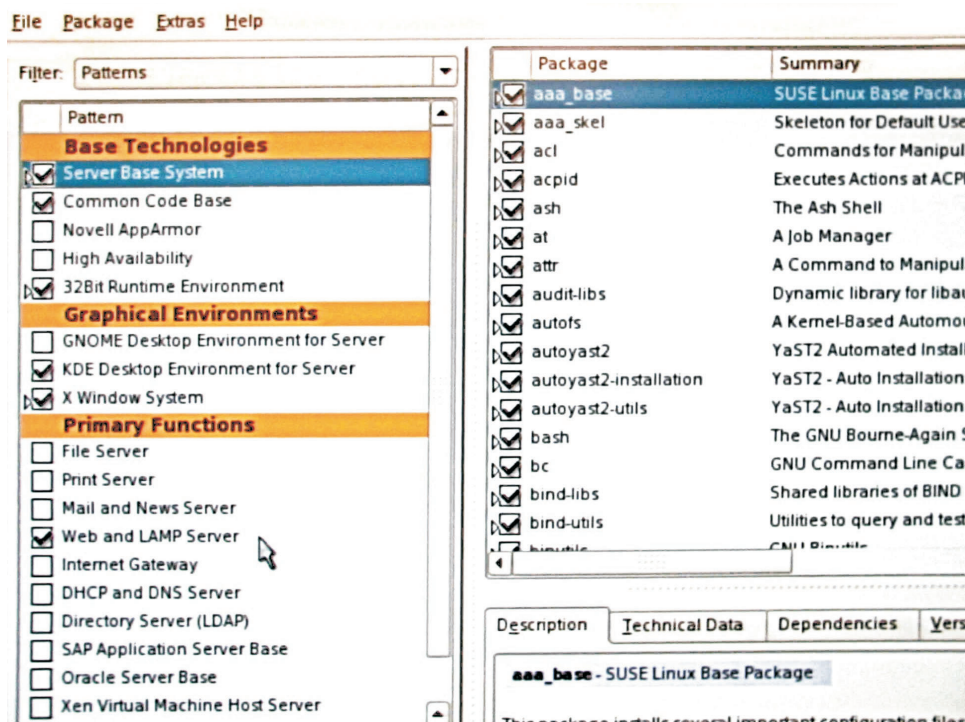

Figure 7. Patterns selection window

- a) Check **Server Base System** (should already be checked).
  - b) Check **Common Code Base**.
  - c) Uncheck **Novell AppArmor**.
  - d) Uncheck **GNOME Desktop for Server**.
  - e) Check **KDE Desktop Environment for Server** (required).
  - f) Check **X Window System**.
  - g) Uncheck **Print Server**.
  - h) Check **Web and LAMP Server**.
- 2) With the Filter: set to **Search**, do the following:
- a) Type `mgetty` in the search window and click **Search**.
  - b) In the right window, check the box to the left of the `mgetty` package.
  - c) Repeat steps 2a and 2b for `expect`.
  - d) Repeat steps 2a and 2b for `net-snmp`.
  - e) Repeat steps 2a and 2b for `minicom`.

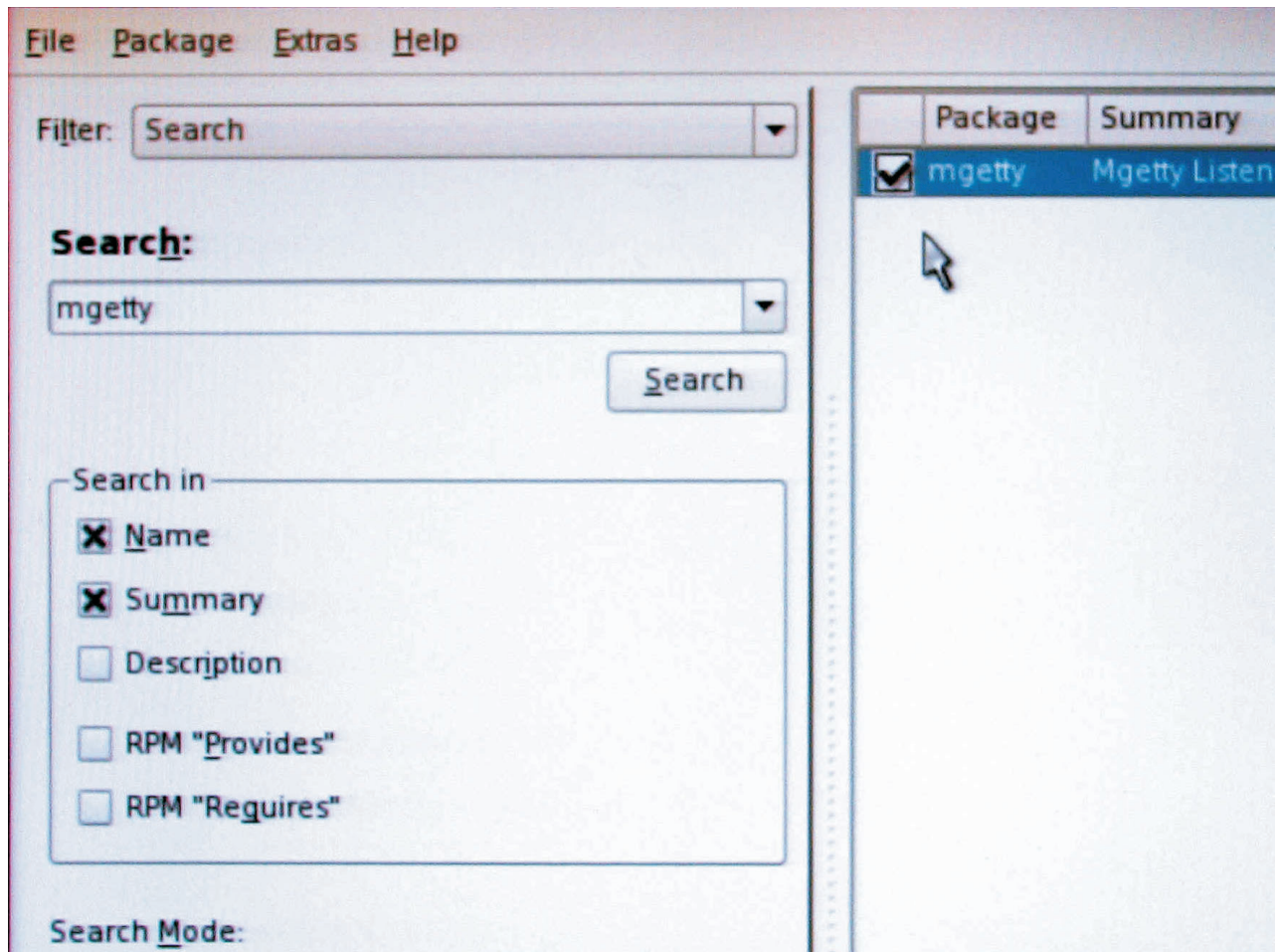

Figure 8. Filter: Search selection window

- 3) Click **Accept** in the lower right of the screen.
- d. Click **Continue** if any Automatic Changes are suggested.
- e. Click **Accept** in the lower right of the screen.
- f. Click **Install** on the Confirm Installation screen. (It may take a long time to prepare the hard disk.)

Insert additional CDs when prompted.

**Note:** During the installation, the system automatically re-boots and presents the initial menu, allow the system to default to the Boot from Hard Disk selection.

4. On the Hostname and Domain Name screen, do the following:
  - a. Type `ibmrsm` for the Host Name. (If you have another Remote Support Manager installed in your intranet, add a number to the name.)
  - b. Enter your Domain Name.
  - c. Uncheck Change Hostname via DHCP.
  - d. Click **Next**.
5. Provide a password for the root user and click **Next**.
6. If the option is present, disable IPv6.
7. On the Network Configuration screen, click **Network Interfaces**.

If you are not sure how to enter network configuration information, check with your network administrator.

The server running the Remote Support Manager must be able to reach the storage subsystems to be monitored, your e-mail (SMTP) server and the Internet. Depending on your network topology this may require one or two network interfaces for this system.

The first Ethernet port is automatically configured for DHCP. You should assign a static IP address for this system.

Click on the name to highlight it and then click **Edit**.

- a. Define a static IP address for this system by doing the following:
  - 1) Click **Static Address Setup** and enter the static IP address and Subnet Mask for the system.
  - 2) Click **Hostname and Name Server** and do the following:
    - a) Verify that the previously entered hostname and domain name are correct.
    - b) Enter the IP addresses of the name servers in your intranet.
    - c) Click **OK**.
  - 3) Click **Routing** and do the following:
    - a) Enter the IP address of the Default Gateway.
    - b) Click **OK**.
- b. Click **Next** to return to the Network Card Configuration Overview and do the following:
  - 1) If your storage subsystems are on a private LAN, you will need to configure a second Ethernet port to be able to access an SMTP e-mail server and the Internet. Additional unconfigured network adapters/ports will appear in the box at the top of the screen. Click the port to configure and then **Edit** to configure additional ports.
  - 2) Click **Next** to exit Network Card Configuration Overview.
  - 3) Click **Next** to exit Network Configuration.

**Note:** It is not necessary to configure the firewall or modem as these will be managed by the RSM for Storage software.

8. On the Test Internet Connection screen, do the following:
  - a. Click **Yes** and **Next**.
  - b. If the test fails, check with your network configuration and verify that the previously entered configuration is correct. You can click **Back** to return to the Network Configuration menus.
  - c. If the test continues to fail contact, your IT support staff. You can resolve the network problem after the installation of the OS has completed. Continue the installation by clicking **No, Skip This Test** and **Next**.
  - d. If the test is successful, you will be given the option to install Online Updates.

These may include security updates and should be installed. Load only the recommended security patches.

**Attention:** If you were required to install any device drivers at the start of the installation, *do not* install any kernel updates.

9. On the Installation Settings screen, click **Next**.
10. On the User Authentication Method screen, select **Local** and click **Next**.

11. On the Add a New Local User screen, click **Next** and **Yes** to the pop-up window. (RSM for Storage will create users when it is installed.)
12. Review the Release Notes and then click **Next**.
13. On the Hardware Configuration screen, you should change the monitor and screen resolution to 1024x768 or 1280x1024 if supported by your monitor. To change the settings click each of the following settings to the right of Monitor under the Graphics Cards section:
  - a. Monitor Type
  - b. Aspect Ratio
  - c. Resolution
14. Click **Next** to exit the Hardware Configuration window.
15. On the Installation Completed screen do the following:
  - a. Check **Disable ZMD Service**.
  - b. Uncheck **Clone this system for AutoYaST**.
  - c. Click **Finish**.
16. On the Login screen, do the following:
  - a. Click Session Type (in the lower left corner of the screen), select **KDE** and click **OK**.
  - b. Log in as user **root** using the previously entered password.
  - c. If you are asked whether you want to make KDE the default for future sessions, click **Make Default**.
17. For any additional steps, refer to the *RSM for Storage - Installation Hints and Tips* document at <http://www.ibm.com/servers/storage/disk/rsm>. Then, Continue with Chapter 3, "Installing RSM for Storage," on page 17.



---

## Appendix C. Installing the RHEL 4 AS, Update 4 or Update 5 operating system

Some System x servers have been tested with RSM for Storage and specific instructions for configuring the BIOS and starting the Linux installation for those servers can be found in the *RSM for Storage - Installation Hints and Tips* document at <http://www.ibm.com/servers/storage/disk/rsm>.

**Note:** Please refer to the *RSM for Storage - Hints and Tips* document for recent updates or corrections to this manual.

---

### Part 1 – RHEL 4 AS, Update 4 or Update 5 installation

Start the installation procedures in the *RSM for Storage - Installation Hints and Tips* document.

The *RSM for Storage - Installation Hints and Tips* document will refer you back to this document. Continue with either Part 2 or Part 3 of these instructions.

Depending on your hardware, there may be additional configuration screens presented that are not referenced here. Contact your IT support staff for assistance.

---

### Part 2- RHEL 4 installation

1. Power on the computer and as the system performs the POST and initialization, insert CD #1 for RHEL 4, U4 or U5 in the CD-ROM. The system should boot from the CD-ROM.
2. Press the **Enter** key to install in graphical mode.
3. It is recommended that you perform the Media Check, especially if you downloaded and burned your Linux installation CDs.
4. Click **Next** on the welcome screen
5. Select your language and click **Next**.
6. Select your keyboard and click **Next**.
7. If presented with the Upgrade Examine screen, select **Install Red Hat Enterprise AS** and click **Next**.
8. Select **Automatically Partition** and click **Next**.
9. Go to “Part 3- RHEL 4 installation.”

---

### Part 3- RHEL 4 installation

1. On the Automatic partitioning screen, if any existing partitions are shown, select **Remove all partitions on this system**, and click **Next**. Click **Yes** if you are asked to confirm removal of existing partitions.
2. On the Disk Setup screen, click **Next**.
3. On the Boot Loader Configuration screen, click **Next**.
4. On the Network Configuration screen, do the following:
  - a. Click **Edit** to configure the first Ethernet port.
    - 1) Uncheck **Configure using DHCP**.
    - 2) Check **Activate on Boot**
    - 3) Enter the IP address and netmask for the RSM for Storage system.

- 4) Click **OK**.
- b. If you require two Ethernet connections in order to connect to both your storage subsystems and your company's e-mail and Internet gateways, highlight the second Ethernet port and click **Edit** to configure, otherwise go to step 5.
  - 1) Uncheck **Configure using DHCP**.
  - 2) Check **Activate on Boot**.
  - 3) Enter the IP address and netmask for the RSM for Storage system.
  - 4) Click **OK**.
- c. Enter the host name and domain for this system (such as ibmrsm01.your.company.com).
- d. Enter the IP addresses of your gateway and domain name servers (DNS).
- e. Click **Next**.
5. On the Firewall Configuration screen, do the following:
  - a. Click **No Firewall**. (The firewall will be managed by the RSM for Storage software.)
  - b. For the Enable SELinux option, select **Disabled**.
  - c. Click **Next** and then **Proceed**.
6. Select any additional language support and click **Next**.
7. On the Time Zone Selection screen, select your time zone and click **Next**.
  - a. Select your time zone.
  - b. Check **System clock uses UTC**.
  - c. Click **Next**.
8. Enter the root password and click **Next**.
9. On the Package Installation Defaults screen, check **Customize software packages to be installed**, and click **Next**.
10. On the Package Group Selection screen check or un-check the following applications as indicated. (Some selections might already be checked.)
  - a. Check **X Window System** (should already be checked).
  - b. Uncheck **Gnome Desktop Environment**.
  - c. Check **KDE Desktop Environment**.
  - d. Check **Graphical Internet**.
  - e. Check **Text-based Internet** (should already be checked).
  - f. Check **Server Configuration Tools** (should already be checked).
  - g. Check **Web Server** (should already be checked).
  - h. Check **Mail Server**. Click **Details for Mail Server** and check **postfix**, then click **OK**.
  - i. Uncheck **Windows File Server**.
  - j. Check **Development Tools**. Click **Details for Development Tools** and check **expect**, then click **OK**.
  - k. Check **Administration Tools** (should already be checked).
  - l. Check **System Tools**. Click **Details** and check **net-snmp-utils**, then click **OK**.
  - m. Uncheck **Printing Support**.
11. Click **Next** to exit the Package Group Selection screen.
12. On the About to Install screen click **Next** to start the installation, click **Continue**, and do the following:



- a. Insert additional CDs when prompted.
  - b. When the installation is complete, remove the CD from the drive and reboot the system.
13. Click **Next** on the Welcome screen.
14. Respond to the license agreement.
15. Set the date and time.
16. Select the monitor type and set the display resolution to a minimum of 1024 X 768.
17. Complete the Red Hat Login information and click **Next**.
18. On the System User screen, click **Next** and then **Continue**.
19. On the Additional CDs screen click **Next**.
20. On the Finish Setup screen click **Next**.
21. On the login screen, do the following:
  - a. Click on **Session** and select **KDE**.
  - b. Log in as root.
22. A sound server information message may appear. Check **Do not show this message again** and then click **OK**.
23. Continue with verification of network connectivity in the next section.



---

## Appendix D. Installing the RHEL 5 operating system

Some System x servers have been tested with RSM for Storage. Specific instructions for configuring the BIOS and starting the Linux installation for those servers can be found in the *RSM for Storage - Installation Hints and Tips* document at <http://www.ibm.com/servers/storage/disk/rsm>.

**Note:** Please refer to the *RSM for Storage - Hints and Tips* document for recent updates or corrections to this manual.

---

### Part 1 – RHEL 5 installation

Start the installation procedures in the *RSM for Storage - Installation Hints and Tips* document.

Unless otherwise noted, these instructions apply to the RHEL 5 base and all updates that are shown as supported in the *RSM for Storage Compatibility Guide*. The *RSM for Storage - Installation Hints and Tips* document will refer you back to this document. Continue with either “Part 2- RHEL 5 Installation” or “Part 3- RHEL 5 Installation” of these instructions. Depending on your hardware, there may be additional configuration screens presented that are not referenced here. Contact your IT support staff for assistance.

---

### Part 2- RHEL 5 Installation

Power on the computer and as the system performs the POST and initialization, insert CD #1 for RHEL 5 in the CD-ROM drive. The system should boot from the CD-ROM.

1. Press the **Enter** key to install in graphical mode.
2. It is recommended that you perform the Media Check, especially if you downloaded and burned your Linux installation CDs.
3. Click **Next** on the Red Hat splash screen
4. Select your language and click **Next**.
5. Select your keyboard and click **Next**.
6. Enter your Installation Number.
7. Depending on the state of the system and whether an operation system was already installed, you may be given several choices:
  - a. On systems that have not previously had an operating system installation, you may be asked if you want to initialize the drive. Click **Yes**.
  - b. If a previous version of Red Hat Linux was installed, select **Install Red Hat Enterprise Linux Server**, and click **Next**. Then select **Remove Linux partitions on selected drives and create default layout**, and click **Next**.
8. Go to “Part 3- RHEL 5 Installation.”

---

### Part 3- RHEL 5 Installation

1. On the Network Devices screen, do the following:
  - a. Click **Edit** to configure the first Ethernet port:
    - 1) Uncheck Use dynamic IP Configuration (DHCP).
    - 2) Uncheck Enable IPv6 support.
    - 3) Enter the IP address and Netmask for the RSM for Storage system.

- 4) Click **OK**.
- b. If you require two Ethernet connections in order to connect to both your storage subsystems and your company's e-mail and Internet gateways, highlight the second Ethernet port and click **Edit** to configure this port as described above.
- c. Select **Set the hostname manually** and enter the complete hostname (including the domain name) for the RSM for Storage system. Example: rsm-01.yourcompany.com
- d. Enter the IP addresses of your gateway and domain name servers (DNS).
- e. Click **OK**.
2. On the Time Zone Selection screen:
  - a. Select your Time Zone.
  - b. Check **System clock uses UTC**.
  - c. Click **Next**.
3. Enter the Root Password and click **Next**.
4. On the first software selection screen:
  - a. **Important:** If the option to enable Virtualization is present, uncheck it. Virtualization interferes with communication with the serial port and modem.
  - b. Select **Customize now**.
  - c. Click **Next**.
5. Uncheck Gnome desktop environment.
6. Check **KDE desktop environment**.
7. Click **Development**.
  - a. Check **Development Tools**.
  - b. Click **Optional Packages**:
    - 1) Check **Expect**.
    - 2) Click **Close**.
  - c. Check **Development Libraries**
  - d. Check **X software Development**
  - e. Click **Optional Packages**
    - 1) Check **libXp-devel**
    - 2) Click **Close**.
8. Click **Servers**.
  - a. Check **Mail Server**.
  - b. Click **Optional Packages**.
    - 1) Check **Postfix**.
    - 2) Click **Close**.
  - c. Uncheck Printing Support.
  - d. Check **Web Server**.
9. Click **Base System**:
  - a. Check **System Tools**.
  - b. Click **Optional Packages**:
    - 1) Check **net-snmp-utils**.
    - 2) Click **Close**.
10. Click **Next**. (Package dependencies will be checked.)

11. Check **Next** and then **Continue** to begin the installation.
12. When packages from all CDs have been loaded you will be prompted to reboot.

## RHEL 5 - Configuration

After the system reboots do the following:

1. Click **Forward** on the Welcome screen.
2. Respond to the license agreement.
3. On the Firewall Configuration screen:
  - a. Select **Firewall: Disabled**. (The firewall will be managed by the RSM for Storage daemon.)
  - b. Click **Forward** and then **Yes**.
4. For the SELinux setting, choose the following:
  - a. Select **Disabled**.
  - b. Click **Forward** and then **Yes**.
5. On the Kdump Screen click **Forward**.
6. Set the date and time and click **Forward**.
7. On the Set Up Software Updates screen:
  - a. You should register your system for software updates, and download any recommended security related updates.
  - b. Note that once the RSM for Storage software is installed, its internal firewall will prevent automatic notification and download of updates. You may wish to periodically disable the internal firewall and manually check for updates.
  - c. When you do check for updates, you should only install recommended security related updates.
8. On the Create User Screen, click **Forward** and then **Continue**.
9. On the Sound Card screen, click **Forward**.
10. On the Additional CDs screen, click **Finish**.
11. If prompted to reboot the system, click **OK**.
12. On the login screen, do the following:
  - a. Click on **Session**, select **KDE** and click **Change Session**.
  - b. Log in as root.
13. If a sound server message appears, check **Do not show this message again**, and then click **OK**.
14. For any additional steps, refer to the *RSM for Storage - Installation Hints and Tips* document at <http://www.ibm.com/servers/storage/disk/rsm>. Then, Continue with Chapter 3, "Installing RSM for Storage," on page 17.



---

## Appendix E. Planning worksheets

The installation and configuration of RSM for Storage requires a variety of information about network setup, contacts, and connections. The worksheets provided in this appendix will help you gather this information so that you can successfully install and configure RSM for Storage.

---

### Worksheet #1: Network setup information for the RSM for Storage server

This information will be used during the installation of the Linux OS. (Check with your network administrator to obtain this information)

Hostname for the server \_\_\_\_\_ (ibmrsm is suggested)

Your company's Domain Name \_\_\_\_\_

Use static IP addresses for all network resources and management systems.

The server that the RSM for Storage software is installed on must have a static IP address.

IP address to be assigned to the server \_\_\_\_\_.\_\_\_\_\_.\_\_\_\_\_.\_\_\_\_

Subnet Mask for the server: \_\_\_\_\_.\_\_\_\_\_.\_\_\_\_\_.\_\_\_\_

Gateway IP address: \_\_\_\_\_.\_\_\_\_\_.\_\_\_\_\_.\_\_\_\_

If a second Ethernet connection is required to reach the Internet and your SMTP server:

Subnet Mask for the second \_\_\_\_\_.\_\_\_\_\_.\_\_\_\_\_.\_\_\_\_

IP address of your Domain Name Server \_\_\_\_\_.\_\_\_\_\_.\_\_\_\_\_.\_\_\_\_

---

### Worksheet #2: Company information

Company Name \_\_\_\_\_

Address #1 \_\_\_\_\_

Address #2 \_\_\_\_\_

---

## Worksheet #3: Connection information for the RSM for Storage system

This information will be used to configure connections to the RSM for Storage system.

IP address of your company's e-mail (SMTP) server \_\_\_\_\_

Location of the server \_\_\_\_\_ (building, floor, city, state)

Country or region server is in \_\_\_\_\_

IP address of the management station running IBM Storage Manager  
\_\_\_\_\_

This information will be used to configure connections to the RSM for Storage system.

If you are using a modem to provide remote access for IBM Support:

Phone number of the modem \_\_\_\_\_

Internal number to dial the RSM modem \_\_\_\_\_

This field should be filled in with the shortest phone number required to dial the RSM modem from inside your company's phone system.

If you are using SSH to provide remote access for IBM Support:

External IP address IBM will use to connection \_\_\_\_\_.\_\_\_\_\_.\_\_\_\_\_.\_\_\_\_\_

Port Number for the above address \_\_\_\_\_

IP address of the external firewall \_\_\_\_\_

**Note:** The default port for SSH connection is 22, however it is recommended that a non-standard port number be used for the external firewall connection.

This port number would then be mapped to the port to be used by the RSM for Storage system (specified below).

SSH port number for remote access to the RSM for Storage system. \_\_\_\_\_

**Note:** The default for this port is 22, but you may assign a different port number.

If your external firewall requires authentication, enter the user ID and password that IBM Support will use to authenticate:

External firewall user ID \_\_\_\_\_

External firewall password \_\_\_\_\_

Port number the RSM for Storage system will use to listen for remote connections from your firewall \_\_\_\_\_

If your network requires an HTTP Proxy to reach the Internet:

Proxy IP Address \_\_\_\_\_

Proxy Port \_\_\_\_\_

Proxy User ID \_\_\_\_\_

Proxy Password \_\_\_\_\_



---

## Worksheet #4: Contact people

This is the person that will receive status e-mail from the Remote Support Manager and will be the default contact for subsystems monitored by the Remote Support Manager:

Name \_\_\_\_\_

E-mail address \_\_\_\_\_

**Note:** You can put more than one e-mail address in this field. Separate each address with a comma.

Primary phone number \_\_\_\_\_

Hours to call primary number \_\_\_\_\_

Alternate phone number \_\_\_\_\_

Hours to call alternate number \_\_\_\_\_

Time zone \_\_\_\_\_

Other contact people may be configured and associated with specific storage subsystems. These contacts will only receive e-mail directly related to those storage subsystems.

**Note:** You can configure up to 20 contact people in the RSM for Storage product.

### Contact #\_\_

Name \_\_\_\_\_

E-mail address \_\_\_\_\_

Primary phone number \_\_\_\_\_

Hours to call primary number \_\_\_\_\_

Alternate phone number \_\_\_\_\_

Hours to call alternate number \_\_\_\_\_

Time zone \_\_\_\_\_

### Contact #\_\_

Name \_\_\_\_\_

E-mail address \_\_\_\_\_

Primary phone number \_\_\_\_\_

Hours to call primary number \_\_\_\_\_

Alternate phone number \_\_\_\_\_

Hours to call alternate number \_\_\_\_\_

Time zone \_\_\_\_\_

### Contact #\_\_

Name \_\_\_\_\_

E-mail address \_\_\_\_\_

Primary phone number \_\_\_\_\_

Hours to call primary number \_\_\_\_\_

Alternate phone number \_\_\_\_\_

Hours to call alternate number \_\_\_\_\_

Time zone \_\_\_\_\_

---

## Worksheet #5: Information for each Storage Subsystem

### Storage subsystem #\_\_

**Notes:**

1. The IBM Machine Type/Model should be eight characters in the format: TTTT-MMM.
2. The Drive Enclosure IBM Serial Number should be seven characters.
3. Copy this section for additional subsystems.

For each drive enclosure attached to the subsystem:

Storage subsystem name \_\_\_\_\_  
IP address of controller #1 \_\_\_\_\_  
IP address of controller #2 \_\_\_\_\_ (if present)  
Storage subsystem location phone number \_\_\_\_\_  
(Phone number that rings at the site where the storage subsystem is located  
This phone number is used by automated systems in IBM to determine the  
service branch for the machine.)  
Location of subsystem \_\_\_\_\_ (building, floor, city, state)  
Country where subsystem is located \_\_\_\_\_  
Contact person for this subsystem \_\_\_\_\_  
IBM machine type and model \_\_\_\_\_ (8 characters:  
TTTT-MMM)  
IBM serial number \_\_\_\_\_ (7 characters)

Table 6. Drive enclosures

Drive Enclosure ID	IBM Machine Type (Product ID)	IBM Serial Number

Table 6. Drive enclosures (continued)

Drive Enclosure ID	IBM Machine Type (Product ID)	IBM Serial Number

---

## Worksheet #6: Information for other SAN devices to be accessible from the RSM for Storage system

Gather the following information for the SAN devices to be accessible from the RSM for Storage system.

**Note:** You can configure up to 10 SAN devices.

Table 7. SAN devices

#	Name	IP Address

# \_\_ Name \_\_\_\_\_  
IP Address \_\_\_\_\_  
# \_\_ Name \_\_\_\_\_  
IP Address \_\_\_\_\_  
# \_\_ Name \_\_\_\_\_  
IP Address \_\_\_\_\_  
# \_\_ Name \_\_\_\_\_  
IP Address \_\_\_\_\_  
# \_\_ Name \_\_\_\_\_  
IP Address \_\_\_\_\_  
# \_\_ Name \_\_\_\_\_  
IP Address \_\_\_\_\_  
# \_\_ Name \_\_\_\_\_  
IP Address \_\_\_\_\_  
# \_\_ Name \_\_\_\_\_  
IP Address \_\_\_\_\_  
# \_\_ Name \_\_\_\_\_  
IP Address \_\_\_\_\_

---

## Appendix F. Filtered events

The following events are not reported to IBM Service. However, you will receive an e-mail from the RSM for Storage system when these events occur.

*Table 8. Filtered events*

<b>Event code</b>	<b>Event text</b>
6200	FlashCopy® repository logical drive capacity - threshold.
6202	FlashCopy logical drive failed.
none	The persistent monitor running on Host xxxxxxx cannot reach the indicated Storage Subsystem.
none	The persistent monitor running on Host xxxxxxx can now reach the indicated Storage Subsystem.
4011	Logical Drive not on preferred path due to ADT/RDAC.



---

## Appendix G. Customizing the firewall

The file `/etc/rsm/rsm-firewall.conf` provides a way to allow access to specific IP addresses from the RSM for Storage system.

IP addresses listed in this file, will always be accessible to all local and remote users of the RSM for Storage system. Include one address on each line of the file as shown below:

```
ADDRESS ip_address
```

OR

```
ADDRESS ip_address/netmask
```

For more specific firewall rules, you can use the keywords `INPUT` and `OUTPUT` to specify an `IPTABLES` rule. Use of the `INPUT` and `OUTPUT` keywords requires that you have experience with the syntax for creating rules for `IPTABLES`.

After changing the `rsm-firewall.conf` file, you need to stop and restart the RSM for Storage software. Enter `rsm-stop` followed by `rsm-start`.

**Note:** Any active alerts will be lost when the `RSM-stop` command is run, so this update should be performed when there are no active alerts.

A second firewall configuration file is used to list IP addresses for IBM's external Web and FTP sites. This file is contained in the `/etc/rsm` directory and is named `rsm-firewall-ibm.conf`. Files in this directory cannot be modified by the Local Service user or the remote IBM user.

The rules defined in this directory allow outbound access to IBM support Web sites and should allow you to access these sites from the RSM for Storage system with out needing to disable the internal firewall. The IP addresses of these sites do change from time to time, and access to a specific site may not be covered by the current set of rules.





---

## Notices

This information was developed for products and services offered in the U.S.A. and other countries or regions.

IBM may not offer the products, services, or features discussed in this document in other countries. Consult your local IBM representative for information on the products and services currently available in your area. Any reference to an IBM product, program, or service is not intended to state or imply that only that IBM product, program, or service may be used. Any functionally equivalent product, program, or service that does not infringe any IBM intellectual property right may be used instead. However, it is the user's responsibility to evaluate and verify the operation of any non-IBM product, program, or service.

IBM may have patents or pending patent applications covering subject matter described in this document. The furnishing of this document does not grant you any license to these patents. You can send license inquiries, in writing, to:

*IBM Director of Licensing  
IBM Corporation  
North Castle Drive  
Armonk, NY 10504-1785  
U.S.A.*

For license inquiries regarding double-byte (DBCS) information, contact the IBM Intellectual Property Department in your country or send inquiries, in writing, to:

*IBM World Trade Asia Corporation  
Licensing  
2-31 Roppongi 3-chome, Minato-ku  
Tokyo 106-0032, Japan*

**The following paragraph does not apply to the United Kingdom or any other country where such provisions are inconsistent with local law:** THIS DOCUMENT IS PROVIDED "AS IS" WITHOUT WARRANTY OF ANY KIND. IBM DISCLAIMS ALL WARRANTIES, WHETHER EXPRESS OR IMPLIED, INCLUDING WITHOUT LIMITATION, THE IMPLIED WARRANTIES OF FITNESS FOR A PARTICULAR PURPOSE AND MERCHANTABILITY WITH RESPECT TO THE INFORMATION IN THIS DOCUMENT.

BY FURNISHING THIS DOCUMENT, IBM GRANTS NO LICENSES TO ANY PATENTS OR COPYRIGHTS

This information could include technical inaccuracies or typographical errors. Changes are periodically made to the information herein; these changes will be incorporated in new editions of the publication. IBM may make improvements and/or changes in the product(s) and/or the program(s) described in this publication at any time without notice.

IBM may use or distribute any of the information you supply in any way it believes appropriate without incurring any obligation to you.

This information contains examples of data and reports used in daily business operations. To illustrate them as completely as possible, the examples include the

names of individuals, companies, brands, and products. All of these names are fictitious and any similarity to the names and addresses used by an actual business enterprise is entirely coincidental.

---

## Trademarks

IBM, the IBM logo, and [ibm.com](http://www.ibm.com) are trademarks or registered trademarks of International Business Machines Corporation in the United States, other countries, or both. If these and other IBM trademarked terms are marked on their first occurrence in this information with a trademark symbol (&regtm; or &tm;), these symbols indicate U.S. registered or common law trademarks owned by IBM at the time this information was published. Such trademarks may also be registered or common law trademarks in other countries. A current list of IBM trademarks is available on the Web at “Copyright and trademark information” at <http://www.ibm.com/legal/copytrade.shtml>.

Adobe and PostScript are either registered trademarks or trademarks of Adobe Systems Incorporated in the United States and/or other countries.

Cell Broadband Engine is a trademark of Sony Computer Entertainment, Inc., in the United States, other countries, or both and is used under license therefrom.

Intel, Intel Xeon, Itanium, and Pentium are trademarks or registered trademarks of Intel Corporation or its subsidiaries in the United States and other countries.

Java and all Java-based trademarks are trademarks of Sun Microsystems, Inc., in the United States, other countries, or both.

Linux is a registered trademark of Linus Torvalds in the United States, other countries, or both.

Microsoft, Windows, and Windows NT are trademarks of Microsoft Corporation in the United States, other countries, or both.

UNIX is a registered trademark of The Open Group in the United States and other countries.

Other company, product, or service names may be trademarks or service marks of others.

---

# Index

## A

- about this document xiii
- activation 25
- address
  - of the IBM director of licensing 87

## B

- browser interface 35

## C

- configuration
  - IBM DS Storage Manager 23
  - RHEL 5 75
  - RSM for Storage 21
- configure SNMP traps 23

## D

- desktop icons
  - Activity Log 33
  - Help 33
  - Manage 33
  - Security Log 33
- desktops 33

## E

- E-mail
  - contacts 34
  - notifications 33

## F

- filtered events 83
- fire suppression xv

## H

- hardware installation 13
- hardware service and support xv
- help pages 38

## I

- IBM
  - director of licensing address 87
- icons 33
  - status summary 38
- installation
  - hardware 13
  - RHEL 5 73
  - SLES10 63
  - SLES11 57
  - updates to RSM for Storage 29

## L

- Linux SLES10 installation 63
- Linux SLES11 installation 57

## M

- modem connectivity 25
- modem performance/failure criteria xvi

## N

- navigation links 38
- network connection topology 7
- network connections 4
- notices
  - general 87
  - used in this document xiii
- notification e-mails 33

## O

- overview 1

## P

- passwords for storage manager 24
- planning for RSM for Storage 1
- planning worksheets 77
- prerequisites
  - hardware
    - modem 3
    - server 2
    - software 4
- products, developed 87

## R

- remote access to modem 25
- RHEL 5
  - configuration 75
  - installation 73
- RSM for Storage 1

## S

- SAN devices 2
- sending alerts to IBM 4
- services offered in the U.S.A. 87
- shell access security 24
- status summary 38
- storage management applications 2
- storage manager passwords 24
- storage subsystems 2
- supported products 2

## T

- trademarks 88
- troubleshooting
  - hardware problems 49
  - operation problems 52
  - tips for System x servers 50

## U

- user IDs
  - admin 33
  - lservice 33
  - rservice 33
- using RSM for Storage 33

## W

- Web sites, related xv
- worksheet
  - for configuration of RSM for Storage
    - company information 77
    - connection information 78
    - contact people 79
    - other SAN devices 82
    - storage subsystems to be monitored 80
  - information of installation of operating system
    - network setup 77
- worksheets 77





Part Number: 00W0178

Printed in USA

GA32-1064-00



(1P) P/N: 00W0178

